



# Liquid Cooling Energy Storage System

**TRENE-P65B261L-E/TRENE-P79B261L-E**  
**TRENE-P99B261L-E/TRENE-P100B261L-E**  
**TRENE-P124B261L-E/TRENE-P125B261L-E**

## User Manual

Version 6.0

[www.solaxpower.com](http://www.solaxpower.com)



QR Manual in this code or  
at [www.solaxpower.com](http://www.solaxpower.com)



# STATEMENT

---

## Copyright

Copyright © SolaX Power Network Technology (Zhejiang) Co., Ltd. All rights reserved.

No part of this manual may be reproduced, transmitted, transcribed, stored in a retrieval system, or translated into any language or computer language, in any form or by any means without the prior written permission of SolaX Power Network Technology (Zhejiang) Co., Ltd.

## Trademarks



**SOLA<sup>X</sup>** and other symbol or design (brand name, logo) that distinguishes the products or services offered by SolaX has been trademark protected. Any unauthorized use of the above stated trademark may infringe the trademark right.

## Notice

Please note that certain products, features, and services mentioned in this document may not be within the scope of your purchase or usage. Unless otherwise specified in the contract, the contents, information, and recommendations presented in this document are provided "as is" by SolaX. We do not provide any warranties, guarantees, or representations, whether express or implied.

The content of the documents is reviewed and updated as needed. However, occasional discrepancies may occur. SolaX retains the right to make improvements or changes in the product(s) and the program(s) described in this manual at any time without prior notice.

The images included in this document are solely for illustrative purposes and may differ based on the specific product models.

For more detailed information, kindly visit the website of SolaX Power Network Technology (Zhejiang) Co., Ltd. at [www.solaxpower.com](http://www.solaxpower.com).

SolaX retains all rights for the final explanation.

# About This Manual

---

## Scope of Validity

This manual is an integral part of the intelligent all-in-one liquid cooling energy storage system. It describes the transportation, storage, installation, electrical connection, commissioning, maintenance and troubleshooting of the product. Please read it carefully before operating.

This manual is valid for the following system models:

- TRENE-P65B261L-E
- TRENE-P79B261L-E
- TRENE-P99B261L-E
- TRENE-P100B261L-E
- TRENE-P124B261L-E
- TRENE-P125B261L-E

### Model description

TRENE-P125B261L-E is used for example.

# TRENE-P125B261L-E

1

2

3

4

5

No.	Definition	Description
1	Product name	TRENE: Refer to the name of AC couple series project.
2	Power	Rated power of the PCS. Value range:65 (65 kW), 79 (79.9 kW), 100 (100 kW), 124 (124.9 kW) and 125 (125 kW).
3	Battery capacity	B261: The battery capacity is 261 kWh.
4	Cooling system	L: Liquid cooling
5	Europe	Conforms to the European Standard





## Target Group

The installation, maintenance and grid-related setting can only be performed by qualified personnel who:

- Are licensed and/or satisfy state and local regulations.
- Have good knowledge of this manual and other related documents.
- A medium-voltage operator is required to obtain any Certifications for High-voltage Electrician.

## Conventions

The symbols that may be found in this manual are defined as follows.

Symbol	Description
 <b>DANGER</b>	Indicates a hazardous situation which, if not avoided, will result in death or serious injury.
 <b>WARNING</b>	Indicates a hazardous situation which, if not avoided, could result in death or serious injury.
 <b>CAUTION!</b>	Indicates a hazardous situation which, if not avoided, could result in minor or moderate injury.
 <b>NOTICE!</b>	Provides tips for the optimal operation of the product.

## Change History

### Version 6.0 (2026-01-19)

Updated "[2.1.2 Appearance and Dimensions](#)" (Round off the values to the nearest integer)

Added "[6.5 Removal of Smoke Detector and Temperature Sensor Covers](#)"

Updated "[3.2.2 Battery Storage](#)" (Modified the description for how often should be battey be charged)

Updated "[13.1 Requirements for OT/DT Terminal](#)" (Changed the separate aluminum wahser and copper washer into copper–aluminum bimetallic washer)

Added "[2.3.1 Supported Power Grid](#)"

Added "[13.1 Installation Video](#)"

#### **Version 5.0 (2025-08-26)**

Updated "[4.1.2 Clearance Requirements](#)" (Added description on the clearance above the cabinet)

Added "[6.4 MSD Installation](#)"

Updated "[5.2 Packing List](#)" (Added MSD plug, and revised the key strings)

Updated "[3.1.1 Forklift](#)" (Added description on the tipping indicator)

Updated "[4.1 Installation Site Selection](#)" (Changed the installation scenario from "outdoors" to "indoors and outdoors", and modified the requirements for distance from polluted areas))

Updated "[2.1.2 Appearance and Dimensions](#)" (Changed the height of the cabinet)

Updated "[6.2 Cabinet Fixing](#)" (Added the method of using screws to secure the cabinet)

#### **Version 4.0 (2025-07-12)**

Updated "[3.1.1 Forklift](#)" (Changed the image of carton to wooden crate and modify the requirements on forklift specification)

Updated "[5.1 Unpacking](#)" (Modified the procedure of unpacking the wooden crate)

Updated "[12 Technical Data](#)" (Modified some parameters, and added the model of TRENE-P99B261L-E)

Updated "[6.1.1 Crane Hoisting](#)" (Modified the image of hoisting)

#### **Version 3.0 (2025-06-09)**

Added information on TRENE-P79B261L-E

Updated "[4.1 Installation Site Selection](#)" (Modified the requirements for the height of the steel foundation and height above the highest water level.)

Updated USA contact information

Ajusted the structure of the entire document, and delete the chapter on LED indicators.

#### **Version 2.0 (2025-04-30)**

Updated "[4.1.2 Clearance Requirements](#)" (Modified the clearance details for both single and multiple cabinet installation)

Updated "[4.3 Additionally Required Materials](#)" (Modified the specification of PE wire and related ring terminal)

Updated "[5.2 Packing List](#)" (Added document and optional parts)

Updated "[6.3 Angle Support Installation](#)" (Modified the distance between the circles drawn on the ground for securing the angle supports)

**Version 1.0 (2025-03-12)**

Updated "[1 Safety](#)" (Added requirements for device transportation, and modified description on PCS safety)

Updated "[4.1.1 Installation Foundation Requirements](#)" (Added description on the optional steel foundation)

Updated "[4.1.2 Clearance Requirement](#)" (Modified the clearance requirement when multiple cabinets are placed side by side)

Updated "[5.2 Packing List](#)" (Changed the number of keys for screen door)

**Version 0.0 (2025-01-16)**

Initial release

# Table of Contents

---

<b>1</b>	<b>Safety .....</b>	<b>1</b>
1.1	General Safety .....	1
1.2	Device Safety.....	2
1.2.1	Cabinet Safety .....	2
1.2.2	Battery Safety.....	3
1.2.3	Liquid Cooling Unit Safety .....	5
1.2.4	PCS Safety .....	6
1.2.5	Utility Grid Safety .....	7
1.3	Electrical Safety .....	7
<b>2</b>	<b>Product Overview .....</b>	<b>10</b>
2.1	Product Introduction .....	10
2.1.1	Functions and features .....	10
2.1.2	Appearance and Dimensions .....	11
2.2	Major Parts Description .....	14
2.2.1	AC Distribution System .....	18
2.2.2	DC Side Battery System.....	20
2.2.3	Power Conversion System.....	22
2.2.4	Environmental Monitoring System .....	23
2.2.5	Other Monitoring Parts .....	24
2.2.6	Fire Suppression System.....	25
2.2.7	Energy Management System .....	26
2.3	Operating Principle .....	27
2.3.1	Supported Power Grid.....	27
2.3.2	Electrical Schematic Diagram .....	29
2.3.3	Working Mode.....	30
2.4	Typical Application Scenario .....	30
2.5	Graphical Symbols .....	31
<b>3</b>	<b>Transportation and Storage .....</b>	<b>33</b>
3.1	Transportation Requirements .....	33
3.1.1	Forklift.....	33
3.1.2	Hoisting .....	35
3.2	Storage Requirements.....	36
3.2.1	Cabinet Storage .....	36
3.2.2	Battery Storage.....	36

<b>4</b>	<b>Preparation before Installation</b>	<b>38</b>
4.1	Installation Site Selection	38
4.1.1	Installation Foundation Requirements	40
4.1.2	Clearance Requirements	42
4.2	Tool Requirements	44
4.3	Additionally Required Materials	45
<b>5</b>	<b>Unpacking and Inspection</b>	<b>46</b>
5.1	Unpacking	46
5.2	Packing List	47
<b>6</b>	<b>Mechanical Installation</b>	<b>49</b>
6.1	Cabinet Handling	49
6.1.1	Crane Hoisting	49
6.1.2	Forklift Handling	50
6.2	Cabinet Fixing	51
6.3	Antenna Installation	56
6.4	MSD Installation	57
6.5	Removal of Smoke Detector and Temperature Sensor Covers	58
<b>7</b>	<b>Electrical Connection</b>	<b>59</b>
7.1	Grounding Connection	60
7.2	Grid Connection	62
7.3	Communication Connection	70
7.3.1	Network Connection	70
7.3.2	Meter Connection	74
<b>8</b>	<b>System Power-on</b>	<b>76</b>
8.1	Checking before Power-on	76
8.2	Powering on the System	77
<b>9</b>	<b>Operation on EMS and SolaXCloud</b>	<b>80</b>
9.1	EMS Screen Login	80
9.2	SolaXCloud APP Login	81
<b>10</b>	<b>Troubleshooting and Maintenance</b>	<b>83</b>
10.1	Powering off the System	83
10.2	Troubleshooting	87
10.3	Maintenance	91
10.3.1	Maintenance of the Cabinet	93
10.3.2	Maintenance of the PCS	93
10.3.3	Maintenance of the Battery Pack	94
10.3.4	Maintenance of the Liquid Cooling Unit	95

11	Dispose of Wasted and Damaged Battery Pack .....	96
12	Technical Data .....	97
13	Appendix .....	100
	13.1 Installation Video .....	100
	13.2 Requirements for OT/DT Terminal .....	100
	13.3 How to Repaint the Cabinet.....	102
	13.3.1 Light Scratches & Small Areas of Stubborn Stains .....	102
	13.3.2 Deep Scratches and Large Areas of Stubborn Stains.....	104
	13.3.3 Logo & Pattern damaged, Dents or Dings.....	106

# 1 Safety

---

## 1.1 General Safety

Before transporting, storing, installing, operating, using and/or maintaining the device, please carefully read and understand the document, and strictly follow the instructions and safety precautions given herein, as well as symbols affixed on the device. The safety instructions herein are only supplements to local laws and regulations.

The operator should not only abide by all safety precautions provided in the document, including but not limited to the "Danger" sign, "Warning" sign, "Caution" sign, and "Notice" sign, but also comply with relevant international, national and local laws, regulations, standards, guidelines and industry rules in the process of transportation, storage, installation, operation, and maintenance. SolaX will not assume any responsibilities for the loss caused by improper operation, or violation of safety standards for design, production and equipment suitability.

SolaX will not be liable for maintenance for possible device failure, device malfunction, or parts damage, nor will the company assume any liability to pay compensation for the possible physical and property damage resulting from the installation environment that does not meet the design requirements.

The device is well designed and tested to meet all applicable state and international safety standards. However, like all electrical and electronic equipment, safety precautions must be observed and followed during the installation of the device to reduce the risk of personal injury and to ensure a safe installation.

SolaX will not assume any responsibilities if any of the following circumstances occur, including but not limited to:

- Device damage due to force majeure, such as earthquake, flooding, thunderstorm, lighting, fire hazard, volcanic eruption, war, typhoon, tornado, etc.
- Device damage due to human cause or caused by strong vibrations from external factors before, during and after installation.
- Device used or operated against local policy or regulations.
- Failure to follow the operation instructions and safety precautions on the product and in this document.
- Installation and use under improper environment or electrical condition.
- Unauthorized modifications to the product or software.
- Device damage caused during transportation by the customer or the third party.
- Storage conditions that do not meet the requirements specified in this document
- Use of incompatible inverters or devices.
- Installation and commissioning operated by unauthorized personnel who are not licensed and /or satisfy state and local jurisdiction regulations.

## 1.2 Device Safety

To prevent personal injury or property damage from improper operation, please carefully read the following installation precautions before installation.

### 1.2.1 Cabinet Safety

#### DANGER!

- According to the local laws and regulations related to high-altitude work, operators must wear PPE, e.g., a helmet, safety belt, or waist harness, when they work at heights, while the other end of the harness must connect to a secure structure to prevent fall incidents.

#### WARNING!

- Please prepare tools that meet the requirements before installation, and check the number of tools after installation, to avoid leaving them inside the equipment.
- Please ensure that the cabinet has been thoroughly secured before operating it. Otherwise, it may cause personal injury or equipment damage due to tilting or collapsing the cabinet.
- Please ensure that the cabinet's vents and cooling system are working properly when it is running. If the vents are blocked, it will lead to overheating, and even equipment damage or fire hazard.
- Please ensure that the cabinet's vents and cooling system are kept away from heat sources.
- Do not drill holes in the device to avoid equipment failure.
- If the circumstances that may cause personal injury or equipment failure occur, such as, fluid flowing into the equipment, stop operation and power off immediately. Otherwise, it may cause a short circuit or damage.
- Do not open the cabinet doors on a rainy or high humid day ( $\geq 80\%$  humidity). If the doors have to be opened on such days, please take proper protective measures.

#### CAUTION!

- Do not use a straight ladder. When electrical work is involved, a wooden ladder or an insulated ladder shall be used.
- The equipment shall not be used to provide a backup power source in the following circumstances:
  - a. Equipment related to life;
  - b. Sensitive precision instruments;
  - c. Home appliances will be faulty in the case of a power failure during operation.

#### NOTICE!

- The signs and messages on the labels and nameplates attached to the device need to be visible and clear.

## 1.2.2 Battery Safety

### DANGER!

- Do not connect the positive and negative poles of a battery together. Otherwise, it may be short-circuited. This will result in an excessive flow of current and large quantities of energy for a short time, and then will cause battery leakage, smoke, the emission of flammable gases, thermal runaway, fire, or even an explosion. Therefore, the battery must be powered off before maintenance.
- If a battery is overheated, it will cause leakage, smoke, release of flammable gases, thermal runaway, fire, or even an explosion. Therefore, please ensure that the installation site shall be well ventilated and kept away from high temperatures.
- Do not dismantle, change, shake, drop, crush, impact, cut, penetrate with a sharp object, or any other ways to damage the battery. Otherwise, it may cause leakage, smoke, emission of flammable gases, thermal runaway, fire, or even an explosion.
- Do not mix different types or makes of the battery. Otherwise, it may cause leakage or rupture, resulting in personal injury or property damage.
- The battery electrolyte is toxic and volatile. Never get in contact with the leaked liquids or inhale gases in the case of the battery leakage or odor, and contact professionals immediately. The professional must wear PPE (including but not limited to safety glasses, safety gloves, gas masks, and protective clothing) before powering off the device, and then contact our company at once after removing the damaged battery.
- Normally, the battery will not release any gases. However, in the following situations: burnt, needle-pricked, squeezed, struck by lightning, overcharged, or subject to other adverse conditions that may cause battery thermal runaway, the battery may be damaged or an abnormal chemical reaction may occur inside the battery, resulting in electrolyte leakage or production of gases. If the battery needs to exhaust flammable gas, safe emission measures must be taken to prevent fire and device corrosion.
- Do not use damaged batteries, and ensure that the installation site must be well ventilated.

### WARNING!

- Please read the document carefully before installation, operation and maintenance.
- Must arrange fire-fighting equipment in advance according to the local laws, regulations, and standards while installing and commissioning the device.
- Please check that there is no damage to the outer packaging before and after unpacking, and in the process of storage and transportation. The battery shall be correctly placed or stacked in accordance with the requirements stipulated on the labels to prevent damaging or scrapping the battery resulting from crushing or falling.

 **WARNING!**

- Must tighten screws securing cables and on the copper bars according to the torque information specified in the document, and check whether they are tightened periodically. For instance, whether there is any rust, corrosion, or any other foreign object on it, and then clean it up if any. Because the loose screw connections may result in excessive voltage drops and large currents, leading to generating a lot of heat and burning the battery.
- The battery should be charged in time after discharge, to prevent battery damage due to overdischarge. If a battery pack is stored for a long time, please periodically recharge it to protect it from damage according to the storage requirements specified in the document.
- Please charge the battery within the specific temperature range because the low temperature may result in a short circuit. Hence, do not charge it when the temperature is below the low limit of the operating temperature.
- Do not use the battery when you find a bulge, or dents on the battery housing, and contact the installer or professional maintenance personnel to dismantle and replace it. The damaged battery must be kept away from other devices and flammable and explosive articles, and do not contact it except for professionals.
- Before operation, ensure that there are no irritating or burning smells around the battery.
- Do not weld or grind near a battery. Because electric sparks or arcs may cause fires.
- Do not step, lead, stand, or set on the battery.

**NOTICE!**

**Transportation requirements for battery:**

- Relevant qualifications for the transport of dangerous goods must be obtained by the forwarding agent engaged in such businesses, and they must strictly abide by the local regulations for the transport of dangerous goods.
- Please check the battery before transportation. If a battery leaks, smells, or is damaged, do refuse to transport it.
- Please handle gently in the process of loading and unloading, transportation, and moving a battery to prevent bumping, and take effective moisture-proof measures to prevent personal injuries and battery damage.
- Unless otherwise specified, do not transport the batteries, which are classified as dangerous goods, together with food, medicine, or other additives on the same means of transport.

**If the battery leaks electrolyte or any other chemical materials, the electrolyte leakage can lead to toxic gases. Therefore, do not contact with them at all times. In case of accidentally coming into contact with them, please do as follows:**

- In case of inhalation: Leave the contaminated area immediately, and seek medical attention at once;
- In case of contact with eyes: Rinse eyes with running water for at least 15 minutes, and seek medical attention;
- In case of contact with skin: Wash the contact area thoroughly with soap, and seek medical attention;
- In case of ingestion: Induce vomiting, and seek medical attention.

**NOTICE!**

**If a fire breaks out where the battery is installed, please do as follows:**

- In case a battery is charging when the fire breaks out, provided it is safe to do so, press the emergency stop button and unplug the power cable;
- In case a battery is not on fire yet, use a water-based fire extinguisher or a carbon dioxide extinguisher to extinguish the fire;
- In case a battery catches fire, do not try to put it out, and evacuate immediately;
- A battery may catch fire when it is heated above 150°C/302°F. If the battery catches fire, please evacuate immediately since it will generate noxious and poisonous gases.

**Recovery of damaged or wasted battery:**

- Dispose of the damaged or wasted batteries according to local laws and regulations instead of placing them in the household trash or curbside recycling bins. Otherwise, it may cause environmental pollution or explosions.
- Ensure that the damaged or wasted batteries are not exposed to the following situations: high temperatures, high humidity, direct sunlight, or corrosive environments.
- Contact a battery recycling company to scrap the battery, which leaks electrolytes, or is damaged or expired.
- Please take protective steps to prevent battery short circuits before moving batteries.
- Please keep away from flammable material storage areas, residential areas, and other population centers when transporting and storing the damaged battery.

### 1.2.3 Liquid Cooling Unit Safety

** WARNING!**

- When the liquid cooling unit is running, please do not touch the internal components of the unit with your hands at will to avoid electric shock or injury from the fan blades.

** CAUTION!**

- If severe vibration or abnormal sound occurs during running or debugging of the unit, please stop all operations and immediately cut off the circuit switch for inspection.
- Do not allow liquids such as water to enter the terminal area of the device during installation and maintenance.
- Only when all the circuit switches are turned off and the internal control board no longer flashes the signal light, can you operate the device circuit and electronic devices, and you must wear anti-static gloves.
- The waste is hazardous. Please properly handle it, and avoid contact of the waste with soil or drainage systems.
- Coolant may cause irritation to eyes, skin, and throat. When handling, wear PPE and use only authorized tools.
- Do not heat the liquid cooling unit in an empty container since it may cause an explosion.

**NOTICE!**

- While injecting the liquid, if the injection process is interrupted manually, restart the process from the beginning when resuming.
- During injection, ensure that the hose in the coolant collection tank is fully submerged and maintains proper coolant flow.
- After completing injection and drainage, thoroughly flush the hoses of the inject machine to remove residual coolant.
- Use a coolant collection tank with a capacity of 20 liters or more, and keep it clean, dry and free from contaminants.

**NOTICE!**

**If the coolant leaks, please avoid contact with it at all times. In case of accidentally coming into contact with it, please do as follows:**

- In case of contact with eyes: Rinse eyes with running water for at least 15 minutes, and seek medical attention;
- In case of contact with skin: Wash the contact area thoroughly with soap, and seek medical attention.

### 1.2.4 PCS Safety

 **DANGER!**

- Only operate the inverter if it is in a technically faultless condition. Operating a faulty inverter may lead to electric shock or fire.
- Do not attempt to open the enclosure without authorization from SolaX. Unauthorized opening of the enclosure will void the warranty and can result in lethal danger or serious injury due to electric shock.
- Make sure that the inverter is reliably grounded before any operation to prevent the risk of electric shock causing lethal danger or serious injury.
- Only qualified personnel can perform the installation, wiring, maintenance of the inverter by following this document and the related regulations.

 **WARNING!**

- Operators must wear PPE while installation and maintenance of the device.
- During operation, avoid touching any parts of the PCS.
- Never connect or disconnect the AC and DC connector while the inverter is running.
- Prior to conducting any maintenance, turn off the AC and DC power and disconnect them from the inverter. Wait for 15 minutes to fully discharge the energy.
- Avoid touching the inverter while it is running, as it becomes hot during operation and may cause personal injuries.

### 1.2.5 Utility Grid Safety

#### NOTICE!

- Only connect the inverter to the grid with the permission of the local utility grid company.

## 1.3 Electrical Safety

#### DANGER!

- Please make sure that the unit is free from any damage before the electrical connection.
- Do not modify, change, or dismantle the device, do not change the power-on and power-off sequences and the installation procedure written in the document, and please properly and correctly operate it.
- Do not power on the device during installation. Otherwise, it may cause a fire, personal injury, or device damage.
- Must remove earrings, rings, bracelets, watches, and any other metal jewelry before operation, to avoid electrical shock, burns, or even death.
- During operation, special insulated tools must be used to avoid electric shock or short circuit failure. The insulated tools' voltage ratings must exceed the system voltage ratings. Please refer to "Technical Data" for system information.

#### WARNING!

- Please wear PPE, such as, protective clothing, insulating shoes, goggles, safety helmets, insulating gloves, etc., when conducting electrical wiring.
- Do not touch the power supply equipment directly, or through conductors or damp objects.
- Do not touch the parts of the equipment of which warning signs are attached, to avoid personal injury or device damage.

#### CAUTION!

- Do not power on the device until it has been installed and confirmed by professionals.
- In the event of a fire, evacuate immediately and call the local fire services.

#### NOTICE!

- Please operate according to the safety code for power station.
- Before installation, it is necessary to set up temporary safety fences or warning lines and hang warning signs in the operation area, to prohibit non-staff from entering here.
- Please make sure that the equipment and its associated switches are off before connecting and disconnecting power cables.

**NOTICE!**

- Please check whether the protective housing and insulating sleeve for an electrical component have been installed correctly after finishing installation, to avoid electric shock.
- Must turn off the output switch of the power supply equipment when maintaining its electrical terminal device and power distribution device.
- If the device is required to be powered off during troubleshooting and diagnosis, please do as the following procedure: power off > electricity testing > connecting grounding cable > hanging warning signs and setting up guardrails.
- Must hang up “Do Not Switch On” warning signs on the relevant switches or circuit breakers before completing maintenance, to prevent power connection. Do not switch on before the fault is solved.
- Do not use water, alcohol, oil, or other solvents when cleaning electrical components inside and outside the device.

**NOTICE!**

**Grounding Requirements:**

- The device's grounding impedance shall meet the requirements of local electrical safety standards.
- The equipment shall be permanently connected to a grounding wire within the building's electrical system. Please check whether the device is reliably grounded before operation. The grounding cable should be removed last while dismantling and maintaining the device.
- Do not start the device if it is not fitted with a grounding conductor.
- All acts against the grounding conductor are prohibited.
- If the device is equipped with a three-pronged socket, make sure that the ground prong is reliably grounded.
- For the device that may generate large contact currents, please make sure that the grounding terminal on the housing has been grounded before powering on, to avoid electric shock.

**Cable Requirements:**

- When deciding the wire diameter, and connecting or wiring cables, follow the local laws, regulations, and codes to ensure safety.
- When external conditions (e.g., placement method, ambient temperature, etc.) change, the cable type must be verified according to IEC-60364-5-52 or local laws, regulations and standards. For instance, whether the cable's current-carrying capacity meets the requirements.
- Before connecting power cables, please make sure that the cable labels are correctly labelled and the cable terminals are well insulated.
- Do not loop and twist cables while conducting electrical wiring. If the length of the power cable is not enough, please replace it instead of joining or welding. Ensure that all the cables of the correct type and size are fully connected and well insulated, and the edges of cable slots and crossing holes are smooth.

**NOTICE!**

- It is recommended to bundle similar cables with cable ties, to ensure that the inside of the device is neat and tidy and to avoid cable jacket damage.
- Please use fireproof mud to seal the threading openings immediately after finishing wiring, to avoid the entry of water vapour or small animals.
- Cables should be kept away from heaters or other heat sources, because a high temperature environment may result in aging and damage to cable insulation.

## 2 Product Overview

---

### 2.1 Product Introduction

Featuring an all-in-one design, the liquid cooling energy storage system integrates high-performance PCS, BMS, high-capacity battery modules, smart EMS, and advanced liquid cooling unit and fire protection mechanism in one cabinet. As a smart outdoor energy storage system, it is easy to install and expand, and is especially applicable to industrial and commercial scenarios.

#### 2.1.1 Functions and features

##### Functions

- The TRENE energy storage system consists of an energy conversion module and an intelligent liquid-cooled lithium-ion battery system, which can store and release power according to the control commands issued by the built-in EMS.

##### Features

- **All-round Protection:** It is equipped with multiple safety protection measures, such as built-in over-voltage, over-current, over-temperature and other protection functions, as well as fireproof materials and level 4 fire safety protection system, allowing it to detect and respond to potential electrical hazards and contain fire in time.
- **EMS Unified Management:** The integrated intelligent EMS system can autonomously adjust the energy storage strategy based on real-time electricity price information, and switch among application scenarios to maximize the efficiency of the system, and accelerate the return on investment cycle.
- **Enduring Stable Performance:** The system supports stable operation under three-phase imbalance conditions, ensuring a stable and reliable power supply in various complex electrical environments through its flexible expandability.

- **Fast Deployment and Scalability:** The highly integrated design minimizes the installation process yet maintains capability for convenient expansion, making it adaptable to commercial and industrial applications of varying scales and requirements.

2.1.2 Appearance and Dimensions

Angle supports installed at front and rear sides

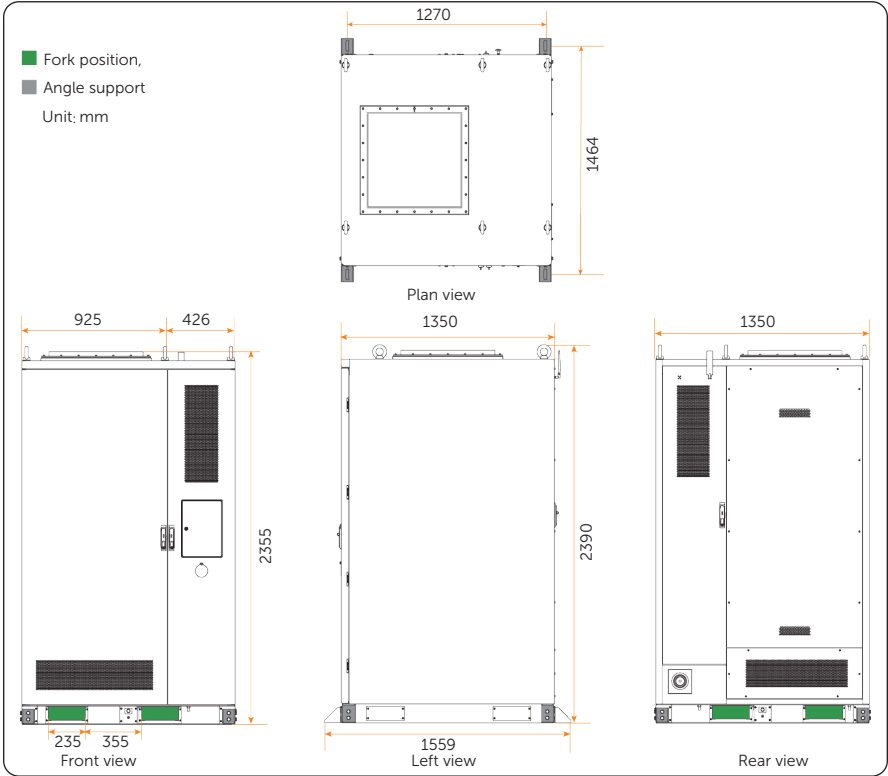

Figure 2-1 Appearance and dimension (1)

Angle supports installed at left and right sides

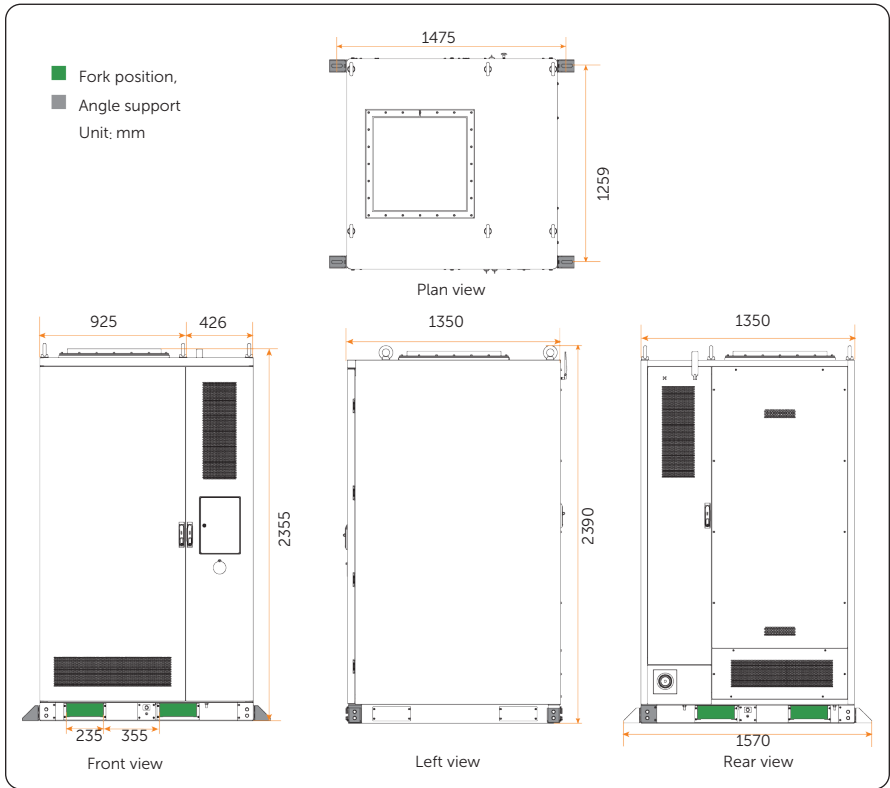

Figure 2-2 Appearance and dimension (2)

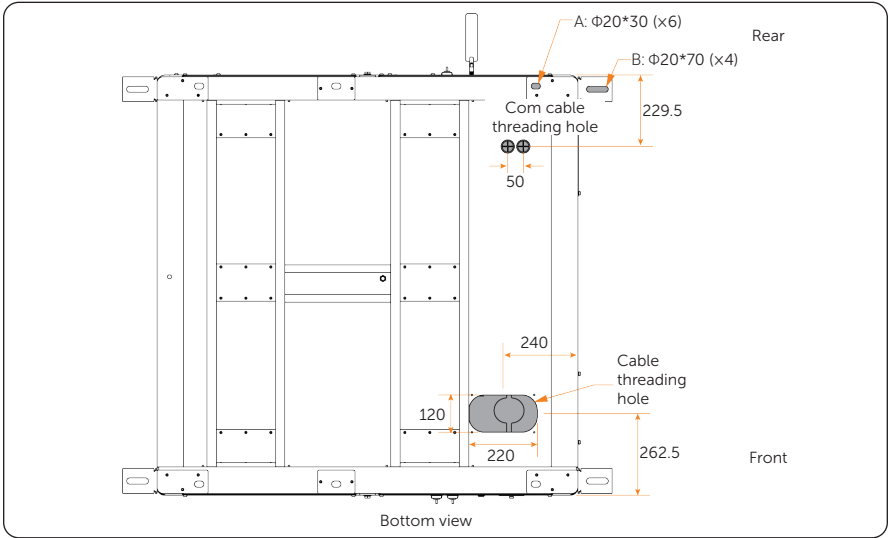

Figure 2-3 Appearance and dimension (3)

**NOTICE!**

- Both A and B are holes for securing the cabinet. Hole B is for cabinet securing through angle supports, while hole A is for direct securing through screws. Select either method to secure the cabinet to the foundation.

## 2.2 Major Parts Description

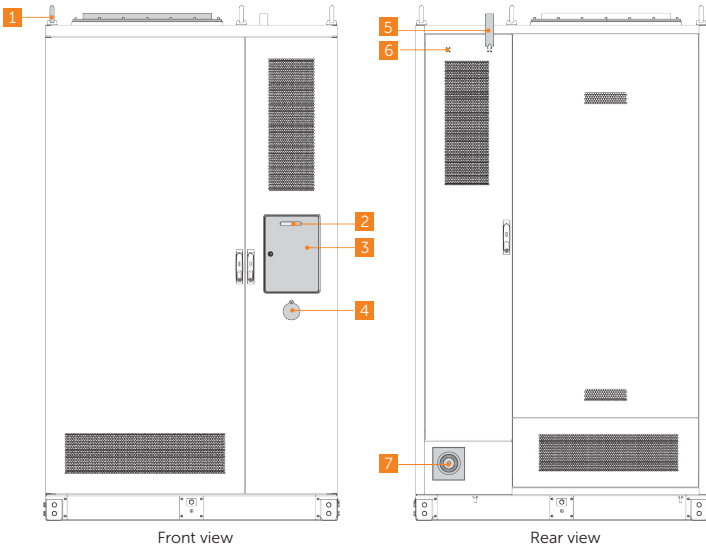



Figure 2-4 Exterior parts (cabinet door closed)

Table 2-1 Parts description (1)

No.	Item	Description
1	Eye bolt	To hoist the cabinet
2	Indicator	To display the operation status of the system. See " <a href="#">Table 2-2 LED indicator description</a> "
3	Display screen	To display information of the entire system
4	Emergency stop button	To shut down the system in emergency circumstances
5	Antenna	4G antenna for expanding data transmission
6	Reserved antenna port	To connect wireless meter
7	Fire hose nozzle	To connect the water supply sources.

Table 2-2 LED indicator description

Indicator Light Status		Definition
Solid yellow		Standby
Solid green		Running
Solid red		Fault

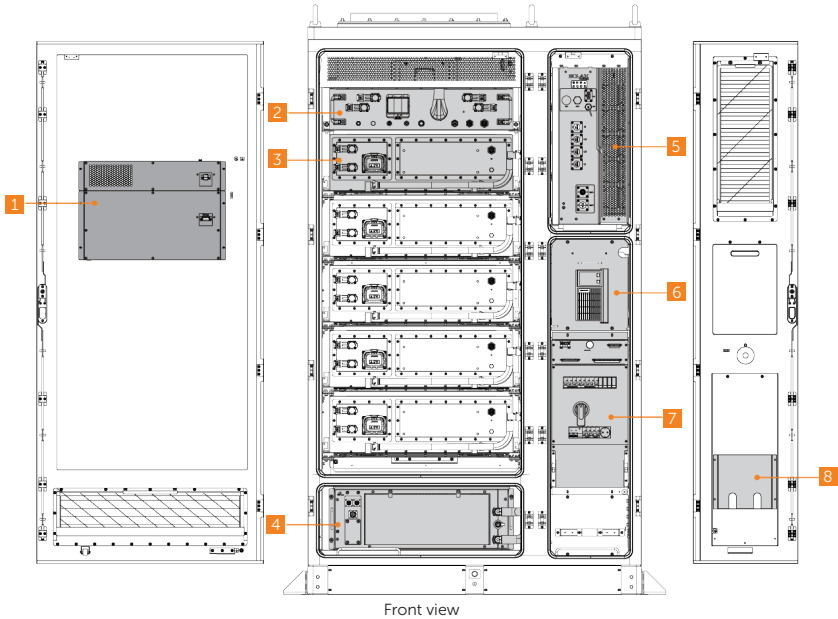

Figure 2-5 Interior parts in the front view (cabinet door open)

Table 2-3 Parts description (2)

No.	Item	Description
1	Dehumidifier	To reduce the level of humidity in the cabinet
2	High-voltage box	To collect current and voltage information on battery tower, and control the charge and discharge of battery pack.
3	Battery pack	/
4	Liquid cooling unit	To cool down or heat the battery packs for optimal operation
5	PCS	/
6	Control area	UPS and IO module can be seen from the front
7	Distribution box	To distribute AC power for the energy storage system.
8	File pocket	To store documents

#### NOTICE!

- The control area is not fully visible. For details, see "Figure 2-7 Control area".

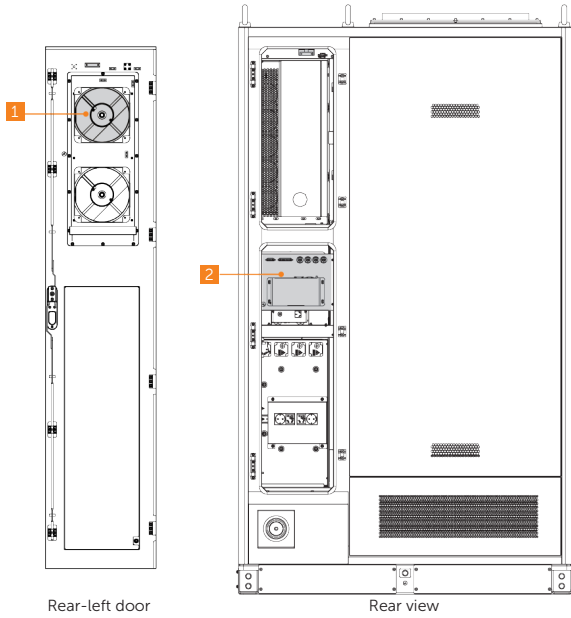

Figure 2-6 Interior parts in the rear view (cabinet door open)

Table 2-4 Parts description (3)

No.	Item	Description
1	Fan	To improve air circulation and dissipate heat when the temperature rises.
2	Control area	EMS, switch and ports for parallel connection can be seen from the rear

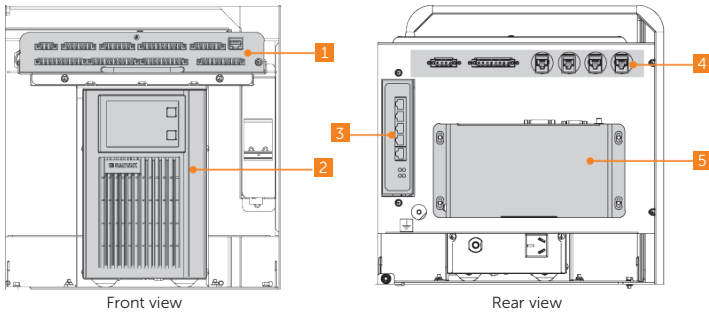

Figure 2-7 Control area

Table 2-5 Parts description (4)

No.	Item	Description
1	IO module	To collect signal and control other modules
2	UPS	To provide backup power for the system
3	Switch	/
4	Ports	To achieve parallel connection
5	EMS	To manage the energy flow and operation of the entire system

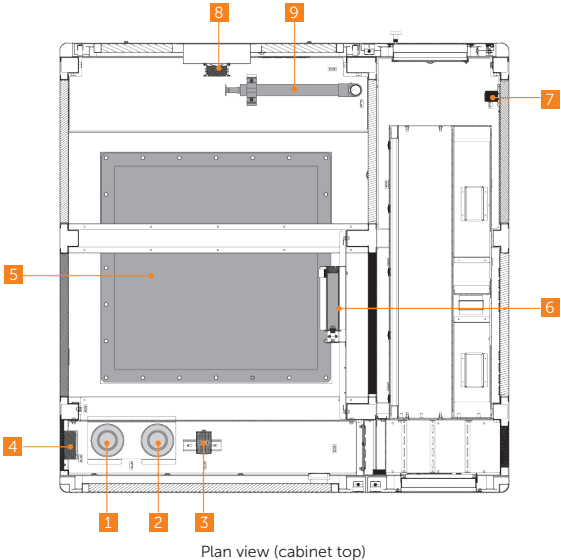

Figure 2-8 Parts on the cabinet top

Table 2-6 Parts description (5)

No.	Item	Description
1	Smoke detector	To detect smoke
2	Temperature sensor	To monitor the temperature for fire suppression system
3	Temperature and humidity sensor	To monitor the temperature and humidity in the cabinet
4	Audible and visible alarm	To alert you when the abnormal conditions occur, such as temperature, smoke.
5	Explosion vent	To release pressure and gases out of the cabinet
6	Automatic fire sprinkler	To control or suppress the spread of fire

No.	Item	Description
7	Temperature control switch	To automatically adjust the temperature inside the cabinet.
8	Explosion-proof fan	To exhaust explosive gases out of the cabinet
9	Waterpipe	For water fire protection

### 2.2.1 AC Distribution System

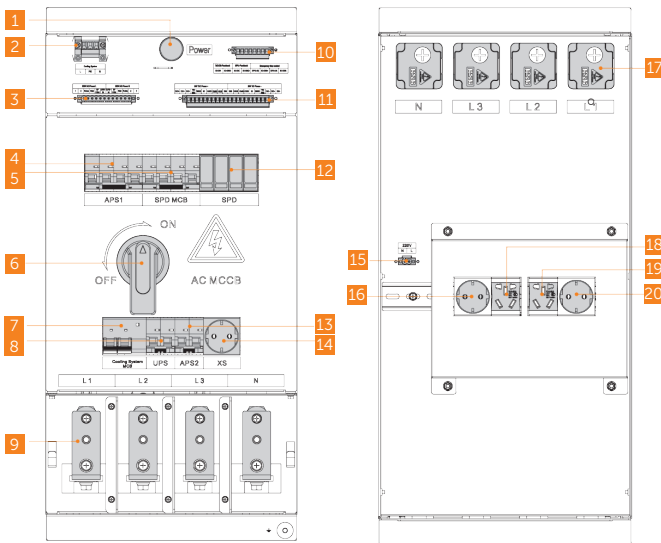

Figure 2-9 Appearance of distribution box

Table 2-7 Distribution box description

No.	Item	Description
1	LED indicator	To display the operation status of the box
2	Power supply port for the cooling unit	To supply power for the liquid cooling unit
3	220V power supply port	To supply 220V power for other devices in the cabinet.

---

No.	Item	Description
4	APS1 breaker	/
5	SPD breaker	/
6	Disconnect switch	To disconnect AC connection
7	Liquid cooling unit breaker	/
8	UPS breaker	/
9	GRID IN wire connector	To connect the system to the grid
10	Emergency stop control	To remotely or manually turn off AC power for emergency
11	24V power supply port	To supply 24V power for parts in the cabinet
12	SPD	To protect the system from voltage spikes
13	APS2 breaker	/
14	220V power supply port	Reserved
15	220V power supply port	To supply 220V power for meter
16	220V power supply port	Reserved
17	GRID OUT wire connector	To connect to PCS for power supply
18	220V power supply port	Reserved
19	220V power supply port	Reserved
20	220V power supply port	To provide power supply for UPS

---

## 2.2.2 DC Side Battery System

### 2.2.2.1 High-voltage Box

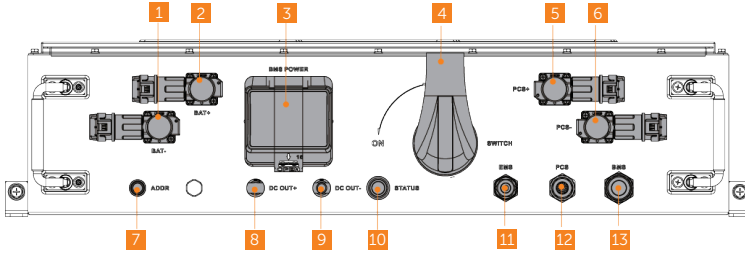

Figure 2-10 Appearance of high-voltage box

Table 2-8 Description of front panel

No.	Item	Description
1	Negative output port	To connect to the battery pack's negative terminal
2	Positive output port	To connect to the battery pack's positive terminal
3	Circuit breaker	To protect the BMS
4	Disconnect switch	To disconnect the device on the DC side
5	PCS+ port	To connect PCS's positive terminal
6	PCS- port	To connect PCS's negative terminal
7	ADDR button	To assign address
8	DC positive output port	Reserved
9	DC negative output port	Reserved
10	Status light	To indicate the working status of BMS
11	EMS COM port	To connect to EMS
12	PCS COM port	To connect to PCS
13	BMS COM port	To connect to BMS

2.2.2.2 Battery Pack

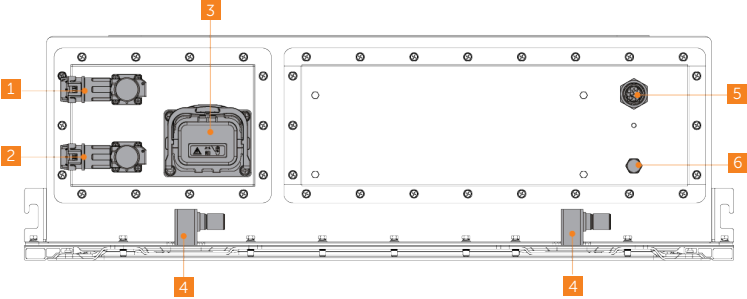

Figure 2-11 Appearance of battery pack

Table 2-9 Description of front panel

No.	Item	Description
1	Positive terminal	To connect to positive power cable
2	Negative terminal	To connect to negative power cable
3	MSD plug	To protect personnel and device safety during maintenance
4	Coolant inlet and outlet	To inject and drain the coolant
5	COM port	To connect to BMS or other battery packs for communication
6	Vent valve	For airtightness testing

### 2.2.3 Power Conversion System

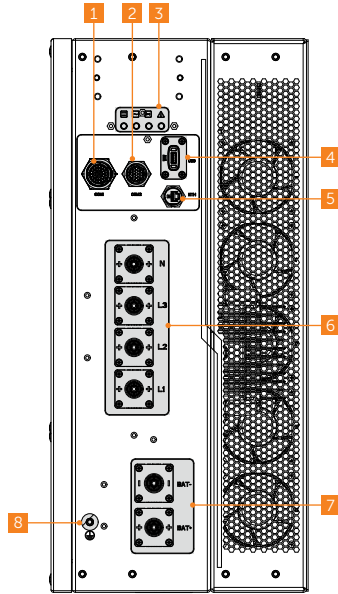

Figure 2-12 Terminals of PCS

Table 2-10 Description of terminals

No.	Item	Description
1	COM1	COM 1 communication terminal
2	COM2	COM 2 communication terminal
3	LED light	To display the operation state.
4	USB	USB terminal
5	ETH	ETH terminal
6	N/L3/L2/L1	Grid connection terminal
7	BAT	Battery connection terminal
8	/	Ground connection point

## 2.2.4 Environmental Monitoring System

### 2.2.4.1 Liquid Cooling Unit

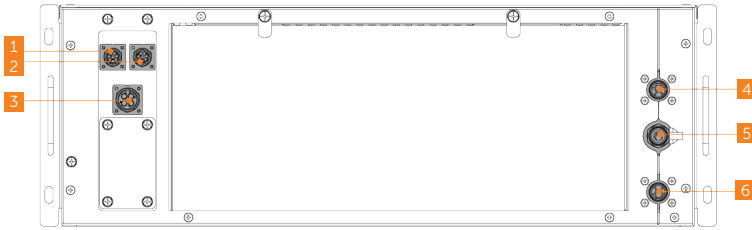

Figure 2-13 Appearance of liquid cooling unit

No.	Item	Description
1	COM port	To communicate with the IO module
2	Debug port	To debug the unit
3	Power port	To supply power for the unit
4	Coolant inlet	/
5	Coolant injecting & draining port	To inject and drain the coolant into and from the unit
6	Coolant outlet	/

### 2.2.4.2 IO Module

**NOTICE!**

- See the label pasted on the cabinet front door for definition on terminals of the IO module.

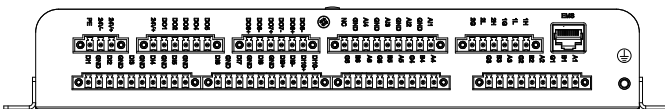
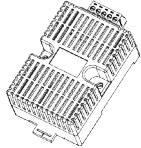
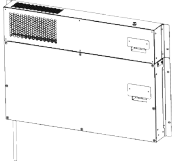
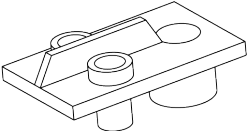
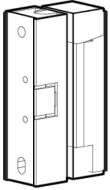
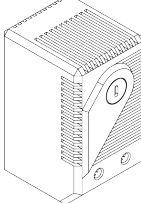

Figure 2-14 Appearance of IO module

### 2.2.5 Other Monitoring Parts

Table 2-11 Description of other environmental monitoring system

Item	Figure
Temperature and Humidity Sensor	 A rectangular electronic sensor module with a grid of small components on top and a connector on the side.
Dehumidifier	 A rectangular unit with a mesh grille on the top left and a control panel on the right side.
Water Sensor	 A flat rectangular board with two circular sensor elements and a small component on the surface.
Door sensor	 Two vertical rectangular components, one with a circular sensor element and a small display or indicator.
Temperature Control Switch	 A rectangular control unit with a large circular dial on the front and a grid of components on top.

---

2.2.6 Fire Suppression System

Table 2-12 Description of fire suppression system

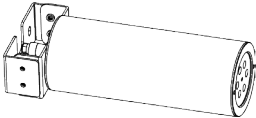
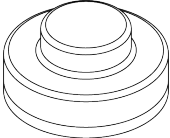
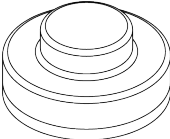
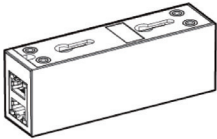
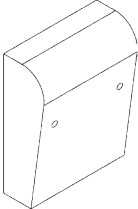
Item	Figure
Automatic Fire Sprinkler	 A line drawing of an automatic fire sprinkler. It consists of a cylindrical body with a mounting bracket on one end and a glass bulb on the other. The glass bulb has a circular pattern on its surface.
Temperature Sensor	 A line drawing of a temperature sensor. It is a cylindrical device with a central protrusion on top and a flange at the bottom.
Smoke Detector	 A line drawing of a smoke detector. It is a cylindrical device with a central protrusion on top and a flange at the bottom, similar in shape to the temperature sensor.
CO Detector	 A line drawing of a CO detector. It is a rectangular device with a mounting bracket on one end and a sensor element on the other.
Audible and Visible Alarm	 A line drawing of an audible and visible alarm. It is a rectangular device with a curved top and a small circular indicator on the front panel.

### 2.2.7 Energy Management System

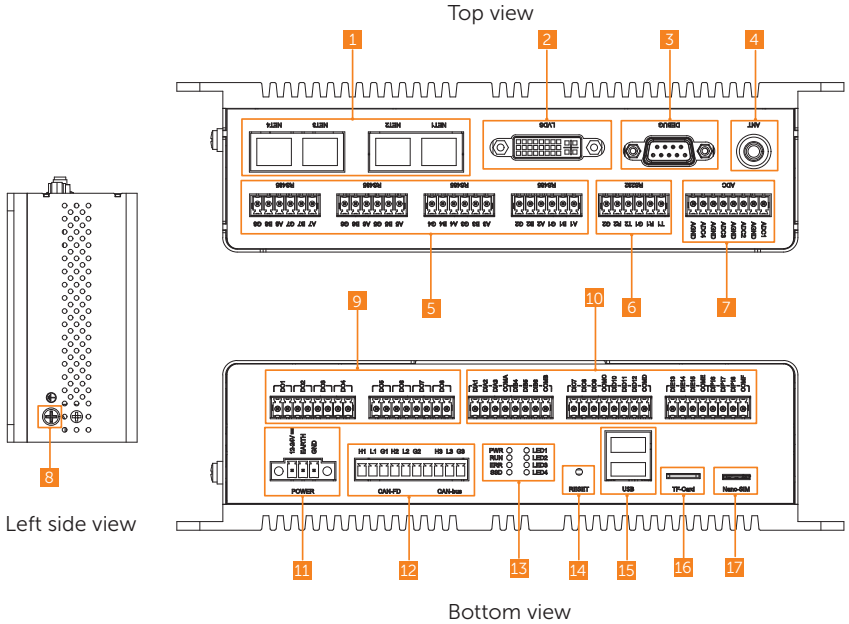

Figure 2-15 Appearance

Table 2-13 Description of appearance

Position	Area	Item	QTY	Description
Top	1	Ethernet terminal (NET)	4	<ul style="list-style-type: none"> <li>NET1: Connected to the switch</li> <li>NET2: Connected to EMS1000 PRO</li> <li>NET3: Reserved</li> <li>NET4: Connected to the router for network</li> </ul>
	2	LVDS terminal	1	Reserved
	3	Debug terminal (DEBUG)	1	Reserved
	4	Antenna socket (ANT)	1	For expanding signal transmission

Position	Area	Item	QTY	Description
Top	5	RS485 terminal	8	<ul style="list-style-type: none"> <li>1-5: Reserved</li> <li>6: Connected to other grid-connected inverter</li> <li>7: Reserved</li> <li>8: Only connected to the meter</li> </ul>
	6	RS232 terminal	2	Reserved
	7	ADC terminal	4	Reserved
Left side	8	Earthing terminal	1	For device earthing
	9	DO terminal	8	Reserved
	10	DI terminal	18	DIA1-DIA3 and COMA, DIB4 and COMB: Dry contact DIB5-COMF: Reserved
	11	Power supply (POWER)	1	12 Vdc-24 Vdc
	12	CAN terminal	3	2 × CAN-FD, and 1 × CAN-bus
Bottom	13	Indicators	8	<ul style="list-style-type: none"> <li>Power status (PWR)</li> <li>Running status (RUN)</li> <li>Error (ERR)</li> <li>SSD status (SSD)</li> <li>LED 1-LED4: Reserved</li> </ul>
	14	Reset button (RESET)	1	For device resetting
	15	USB socket (USB)	2	For device update
	16	TF card socket (TF Card)	1	For firmware programming
	17	Nano-SIM card socket (Nano-SIM)	1	For 4G communication

## 2.3 Operating Principle

### 2.3.1 Supported Power Grid

There are different ways of wiring for different grid systems. TT / TN-S / TN-C-S are shown as below. Please confirm with SolaX whether other grid systems are applicable or not.

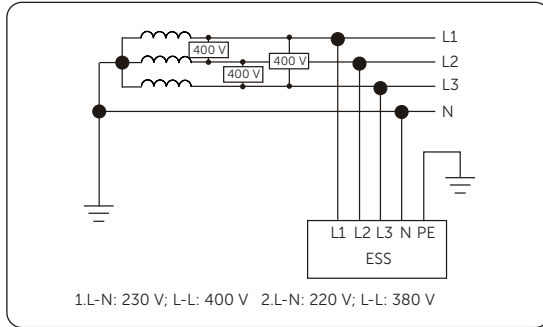

Figure 2-16 Supported power grid-TT

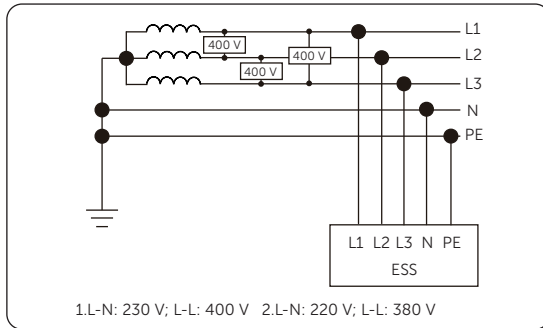

Figure 2-17 Supported power grid-TN-S

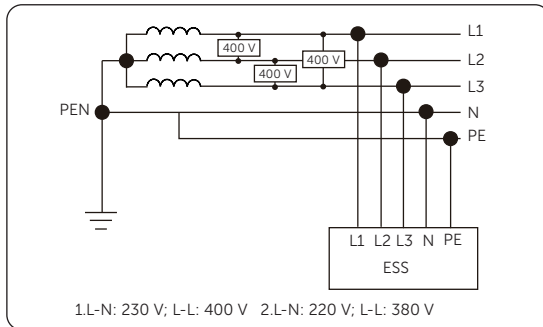

Figure 2-18 Supported power grid-TN-C-S

### 2.3.2 Electrical Schematic Diagram

The Electrical Schematic Diagram label is pasted on the middle of the front cabinet door.,

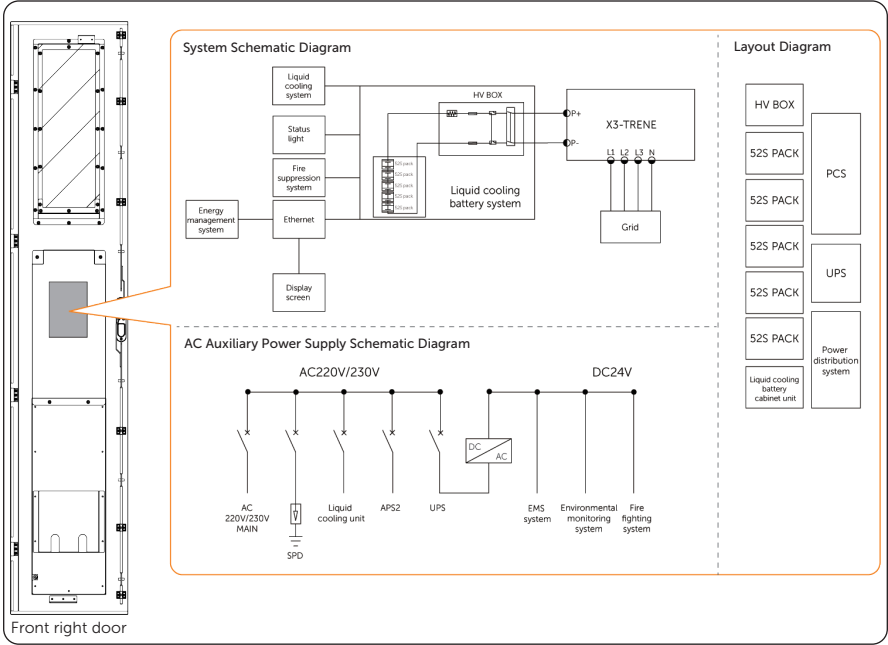

Figure 2-19 Position and content of the label

**NOTICE!**

- In an off-grid situation, the current will vary due to the types of electrical loads. The common electrical load can be classified into following types, resistive load, inductive load, capacitive load, half-wave load, etc. Therefore, the types of electrical loads shall be fully considered when designing and configuring a system. In the case of a half-wave load, the load power shall not exceed 1 kW; in the case of an uncertain electrical load, please contact the supplier for evaluation of output supply to special loads.

### 2.3.3 Working Mode

The liquid cooling energy storage system offers 3 working modes: charging, discharging and standby, and can store and release energy according to EMS commands.

Table 2-14 Working mode description

States	Description
Charging	The EMS controls the PCS to charge the battery and store surplus energy in the battery.
Discharging	When the grid is insufficient to supply the load, the system needs to control the battery to supply power for the load, in which case the energy stored in the battery is converted by the PCS to feed the load.
Standby	Power on without performing work.

## 2.4 Typical Application Scenario

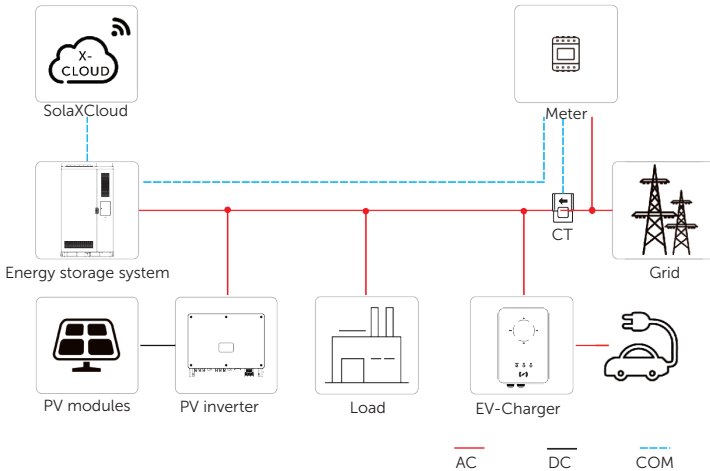

Figure 2-20 System overview diagram

#### NOTICE!





- An external communication cable should have shielding function.

Table 2-15 System item description

Item	Description
Energy storage system	"ALL-IN-ONE" intelligent outdoor energy storage system
Meter/CT	The meter/CT is used for import/export or consumption readings, and manages the battery charge/discharge accordingly for smart energy management applications.
EV-Charger (Optional)	The system can communicate with SolaX EV-Charger to form a storage and EV charging energy system, thus maximizing the utilization of energy.
Grid	400/230 a.c. V and 380/220 a.c. V grid are supported.
PV Inverter	The PV inverter converts the direct current (DC) generated by solar panels into alternating current (AC) that is compatible with the power grid, and to facilitate the bidirectional flow of electricity, thereby maximizing the efficiency of solar energy utilization and providing grid support.
SolaXCloud	SolaXCloud is an intelligent, multifunctional monitoring platform that can be accessed either remotely or through a hard wired connection. With the SolaXCloud, the operators and installers can always view key and up-to-date data. Commercial platform can be connected through EMS1000 connection (EMS1000 is integrated into the cabinet).

## 2.5 Graphical Symbols

Table 2-16 Symbol description

Symbol	Description
	CE mark of conformity
	TUV certification
	Protective grounding point
	Grounding point

Symbol	Description
	Caution, hot surface. The enclosure temperature may be high while running. Therefore, do not contact to avoid scalding.
	Danger, electric shock. Do not touch the device after it is powered on. Otherwise, an electric shock may occur.
	Danger. Due to possible risks, do not touch the device after it is powered on.
	Observe enclosed documentation.
	The device cannot be disposed together with the household waste.
	Do not operate the system until it is isolated from mains and battery.
	Danger of high voltage. Do not touch live parts for 15 minutes after disconnection from the power sources.
	The battery system must be disposed of at a proper facility for environmentally-safe recycling.
	The battery module may explode. The rechargeable battery can become hot during operation. Avoid touch during operation.
	Keep the device away from children.
	Keep the device from open flames or ignition sources.

---

# 3 Transportation and Storage

---

## 3.1 Transportation Requirements



- Please be careful to avoid physical collisions during transportation. Do not place the equipment upside down, be exposed to water, etc., which may result in equipment damage, or even a fire or an explosion.

### NOTICE!

- The device must be transported in its original packaging. SolaX will not be held responsible for any damage to the inverter caused by improper transportation or by transportation after it has been installed.
- Please strictly comply with the transportation requirements of the warning signs on the packaging and equipment.
- To reduce product damage caused by shocking, tilting or impacting during transportation, it is recommended to consider sea or road (with better conditions) transport instead of rail and air transports.
- Relevant qualifications for the transport of dangerous goods must be obtained by the forwarding agent engaged in such businesses, and they must strictly abide by the local regulations for the transport of dangerous goods. Please check the battery before transportation. If a battery leaks, smells, or is damaged, do refuse to transport it.

### 3.1.1 Forklift

- Please confirm that the forklift's load-bearing capacity is  $\geq 5$  t before using it.
- The forklift should meet the following requirements: length of fork blade  $> 1.4$  m, width of fork blade between 36 cm and 60 cm, and thickness of fork blade between 2 cm and 9 cm.

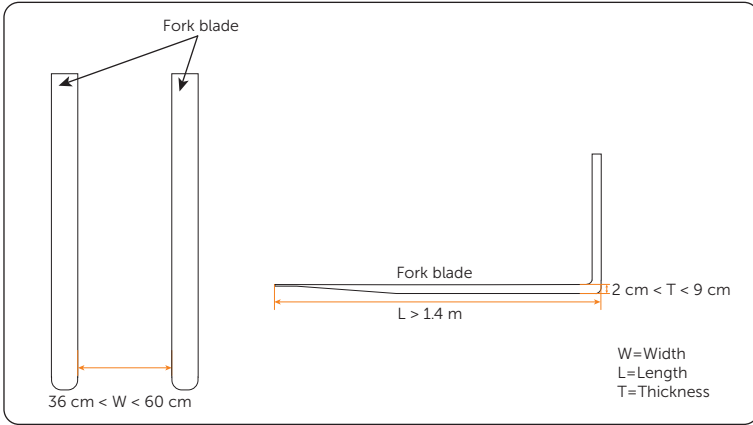

Figure 3-1 Forklift requirements

- Before moving the device, please pay attention to the center of gravity position of the load, and fully secure the load on the forklift by securing measures, such as ropes or bindings. In addition, please designate a person to supervise for safety concerns during transportation.
- Before unpacking, please accurately insert the fork blade into the fork holes on the crate when moving the device.

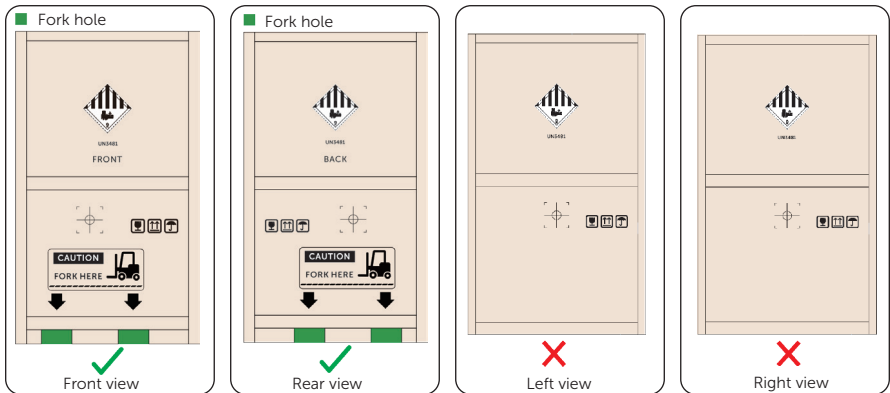

Figure 3-2 Fork holes (wooden crate)

- For specific fork holes after unpacking, please refer to "6.1 Cabinet Handling".
- The equipment can only be transported by forklift before unpacking.
- During transportation, the inclination angle of the cabinet before and after unpacking shall be:  $\alpha \leq 15^\circ$ . Before unpacking, if you see the indicator turns red on the label, do not unpack it, and contact SolaX for solution.

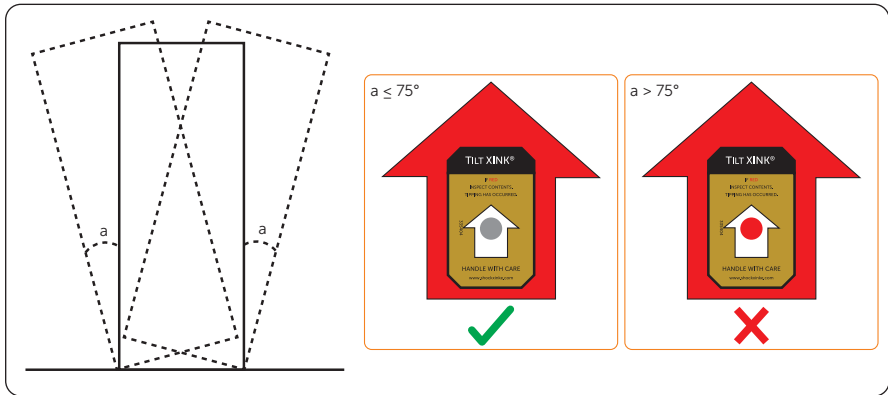

Figure 3-3 Inclination angle requirement during transportation

**WARNING!**

- In the case of a  $a > 15^\circ$ , the cabinet must be left to settle for 4 to 24 hours after delivery to the destination, to avoid the return of lubricating oil in the compressor and the incorrect flow direction of refrigerant. Otherwise, the compressor might not be operating smoothly or even be damaged due to the lubricating oil flowing into the cylinder or coil cavity, or the compressor would not be operating smoothly due to the abnormal return of the refrigerant.

### 3.1.2 Hoisting

- A hoist operator with good operational skills and safety awareness, who must be trained and certified, shall be operated according to the local laws and regulations.
- After unpacking, the following requirements must be met when working with cranes and lifting ropes: crane hoisting capacity  $\geq 5$  t, hoisting operating radius  $\geq 2$  m.
- Before hoisting, please check:
  - » Lifting tools are complete, tested and fully secured.
  - » The device door is closed and locked to avoid accidental opening.
  - » The lifting rope's quality must meet standards, and it shall be fully secured, to avoid falling and fraying.
- Do not hoist outdoors in rain, snow, wind and other bad weather.
- It is recommended to hoist devices in sequence and to ensure that the hoist moves in the same direction.

## 3.2 Storage Requirements

### 3.2.1 Cabinet Storage

- For long-term storage, do not remove the original packaging and check the packaging regularly.
- Please strictly comply with the storage requirements of the warning signs and other information on the packaging to avoid device damage.
- Storage temperature: -20°C to +60°C.
- Relative humidity for device storage: 5%–95%.

#### NOTICE!

Since the batteries have been installed in the cabinet in the factory, the storage requirements for the battery must also be abided by when storing the cabinet.

### 3.2.2 Battery Storage

#### DANGER!

- The battery must be stored indoors, which the environment should meet the following requirements: 1. Avoiding direct sunlight and keeping out of rain; 2. Dry and well-ventilated; 3. Keeping away from heat and fire sources; 4. Keeping away from radiation; 5. Keeping away from chemicals; 6. Keeping away from dust and metal conductive dust; 7. Being equipped with fire facilities.
- Batteries must be stored in accordance with the requirements of the warning signs and other information on the packaging.
- Do not store with any other electronic equipment, chemicals, or other items that may cause interference or danger.
- Please pay attention to the height when stacking batteries to avoid deforming or damaging the battery at the bottom.

#### NOTICE!

- Do not store the batteries for a long time. If long periods of storage are unavoidable, please recharge it periodically to avoid battery damage. For details, see "[10.3.3 Maintenance of the Battery Pack](#)".

- Regarding with the storage information, see the following table:

Table 3-1 Storage information

Storage Temperature Range	Recharge Frequency
50°C to 60°C	Every 3 months
30°C to 50°C	Every 6 months
-20°C to 30°C	Every 12 months

- Relative humidity for device storage: 5%–95%.
- If the battery has been stored for more than 12 months, it must be checked and tested by professionals before use.

# 4 Preparation before Installation

---

## 4.1 Installation Site Selection

The installation site is critical to the safety, service life, and performance of the device, and it should be convenient for electrical connections, operation, and maintenance. Therefore, the installation site should be selected according to the *NFPA 855 Standard for the Installation of Stationary Energy Storage Systems* and the local laws and regulations.

The installation site shall meet the following requirements:

- **Laws, regulations and industry standards:** The selection of installation sites must strictly comply with local laws, regulations, and related industry standards.
- **Fire safety:** Fire extinguishers must be configured at the installation site according to the local fire codes, and a port for the water fire extinguishing system shall be reserved.
- **Installation area:** It is recommended to install the cabinet outdoors. If local regulations permit indoor installation, please ensure there is sufficient space for ventilation, heat dissipation, and maintenance.
- **Safety spacing:**
  - » The installation distance between the device and residential areas, population centers, or production buildings should meet the requirements of the local fire codes and standards.
  - » If the safety spacing cannot be met, a firewall that meets the requirements of the local fire codes must be built between the device and adjacent buildings. During the planning phase, it is crucial to consider the space for transportation, installation and maintenance of the device.
- **Flood and waterlogging prevention:**
  - » Avoid low-lying and flood-prone areas. The installation site that the device is to be located must be at least 250 mm higher than the highest water level in history.
  - » Since winds and wind-driven waves from rivers, lakes, and seas can affect the device, the foundation must be built at least 0.6 m higher than the maximum wave height in history.
  - » If a large amount of water flows in or through the energy storage power station, drainage facilities should be set up.
  - » If the installation site is prone to water accumulation, take waterproof measures, including but not limited to installing water baffles, configuring a drainage system, or raising the height of the foundation to prevent device damage.
- **Avoid liquid intrusion:** The installation area should be far away from the area

where liquid is likely to be generated or leaked to avoid device failure.

- **Good transportation:** Good transportation for the installation site.
- **Reserve space:** During the planning phase, please consider the space for capacity expansion or connection in parallel in the future.
- **Avoiding bad soil:** Do not install devices on the undesirable soil that are prone to deformation and settlement.
- **Keeping away from salt-damaged and polluted areas:** Keep the cabinet away from coastlines and pollutants. If such conditions are unavoidable, please contact SolaX for advice before installation.

Table 4-1 Installation spacing requirements

Installation Site	Recommended Range
Distance from coastal areas	> 2000 m
Distance from heavy pollution sources, such as smelters, coal mines, thermal power plants	> 1500 m
Distance from moderate pollution sources, such as chemical plants, rubber plants, and electroplate factory	> 1000 m
Distance from light pollution sources, such as food processing plants, leather processing plants, heating boiler factory, slaughter houses, dumping sites, and sewage treatment stations	> 500 m

#### NOTICE!

- If the recommended distance range cannot be satisfied, contact SolaX.
  - If the cabinet is installed in polluted areas, please clean the cabinet exterior regularly every 1 to 3 months, or perform cleaning more frequently in easily polluted areas.
  - Do not use acidic or alkaline cleaning agents, and make sure to rinse the cabinet thoroughly with clean water after cleaning.
- **Additional fence:** For security reasons, the installation area should be surrounded by locking fences or walls accessible to qualified persons only.
  - **Installation environment requirements:**
    - » Temperature: -30°C to +55°C.
    - » Relative humidity: 0–100% RH.
    - » Altitude: Below 3000 meters.
    - » Good ventilation.
    - » Keep away from sandy and dusty environments.
    - » Keep away from high temperature environment such as heat source and fire source, etc.
    - » Keep away from flammable and explosive materials and areas with dust.
    - » Keep away from corrosive substances.
    - » Keep away from strong electromagnetic fields and antenna.

- » Keep away from strong vibration and noise sources.
- » Keep away from areas with radiation.
- » Keep away from areas with metal conductive and magnetic dust.
- » Keep away from areas that produce or have toxic and harmful gases.
- » Keep away from environments that are prone to microbial growth.

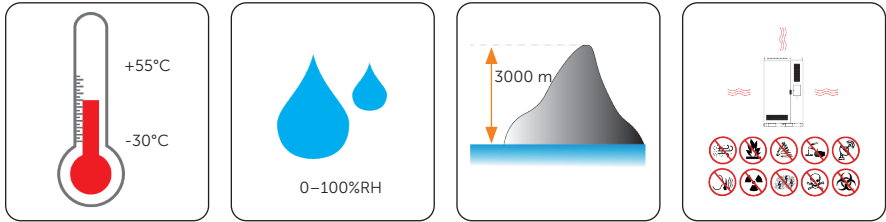

#### 4.1.1 Installation Foundation Requirements

##### Standard Installation Foundation

The requirements for foundation are shown as follows:

- Type of foundation material: 1. Non-combustible materials such as solid bricks or concrete; 2. Steel.
- The bottom of the foundation pit must be strengthened and filled. The surface of the foundation shall be solid, flat and level (horizontal error  $\leq 3$  mm, tilt angle  $\leq 5^\circ$ ). Sunken or tilted foundation is not acceptable.
- The foundation's bearing capacity shall exceed 5 t. Otherwise, a retest is required.

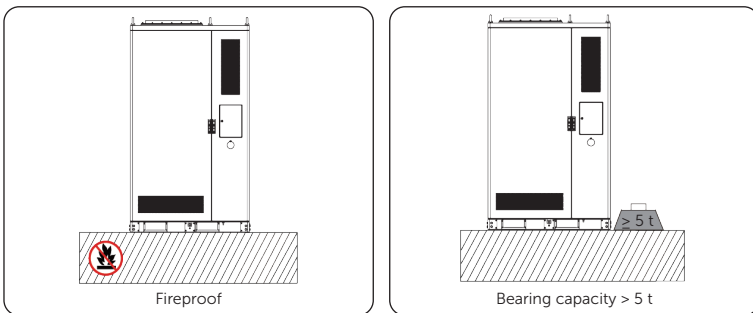

Figure 4-1 Foundation requirement

- A qualified drainage facility, of which the drainage capacity meets the requirements of the heaviest rain records in local history, shall be established according to the local geological conditions and municipal drainage standards.

- Reserve a trench or cable entry hole during the design phase.
  - Avoid cables buried underground when constructing the foundation.
  - The foundation drawing is only for reference. Operators shall recheck and revise it according to the environment, geological conditions, seismic requirements, etc. of the installation site
- » Angle support at the front and rear side:

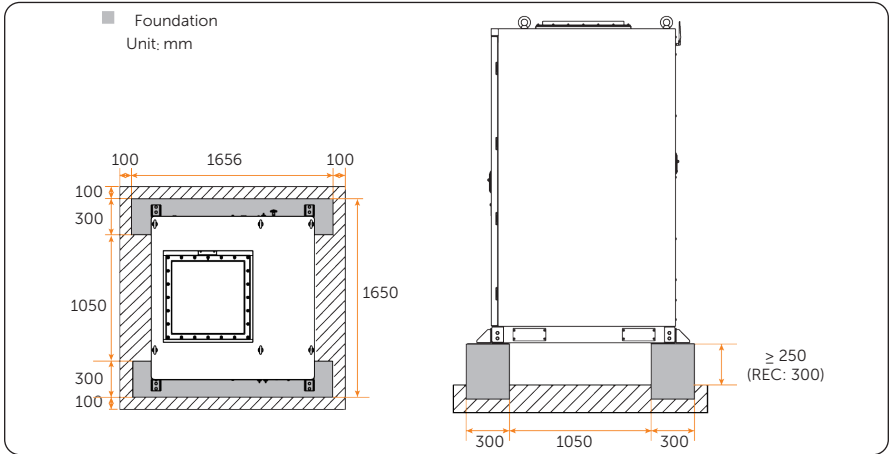

Figure 4-2 Foundation requirements for angle supports installed at front and rear sides

- » Angle support at the left and right side:

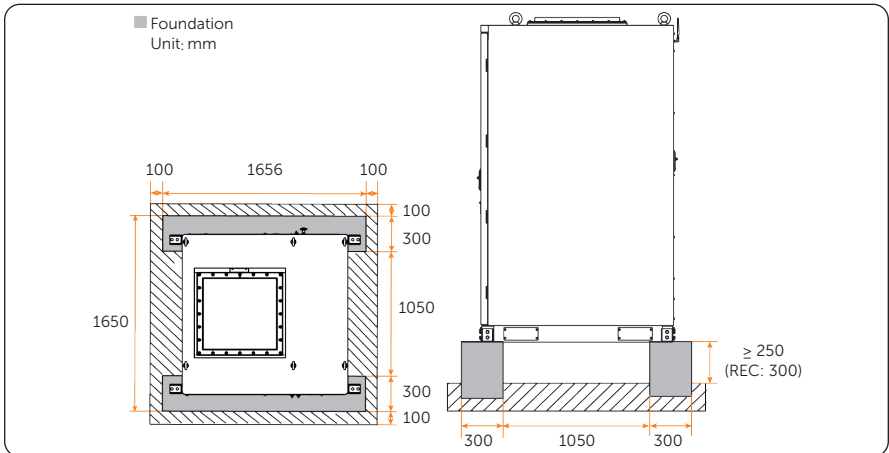

Figure 4-3 Foundation requirements for angle supports installed at left and right sides

### 4.1.2 Clearance Requirements

#### Single Cabinet

For a single cabinet, reserve a space of at least 100 mm at the left, 500 mm at the right side, 1500 mm on the top, 1000 mm in the rear, and 2000 mm in the front for ease of maintenance.

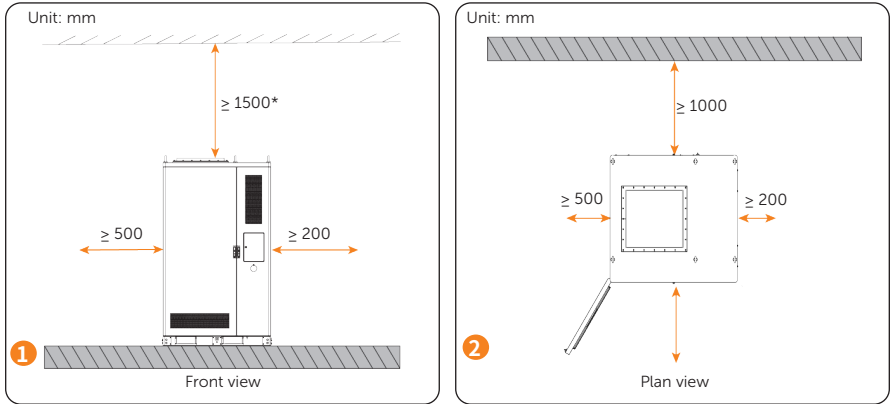

Figure 4-4 Clearance requirements for a single cabinet

#### NOTICE!

\*: 1500 mm is the minimum clearance for crane operation. The actual clearance should be determined by heat dissipation and disassembly requirements.

\*: To facilitate maintenance with SolaX assembly and disassembly tools, we recommend leaving a space of at least 2000 mm in front of the door.

#### Multiple Cabinets

When cabinets are placed in row, each two cabinets in the same row can either be placed close to each other, or be placed 100 mm away from each other.

If the cabinets are placed in the same direction, make sure reserve a space of at least 2000 mm in the front of each row of cabinet; If the cabinets are placed in the opposite direction, beside reserving a space of 2000 mm in the front, reserve a space of at least 1000 mm between the back of each two rows of cabinets.

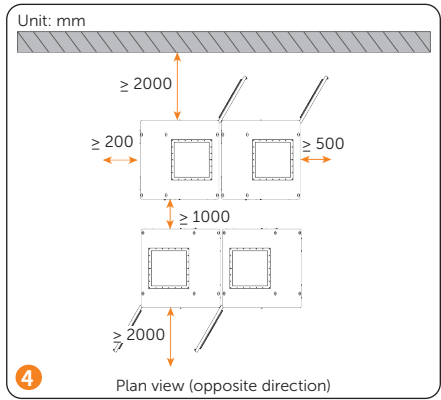
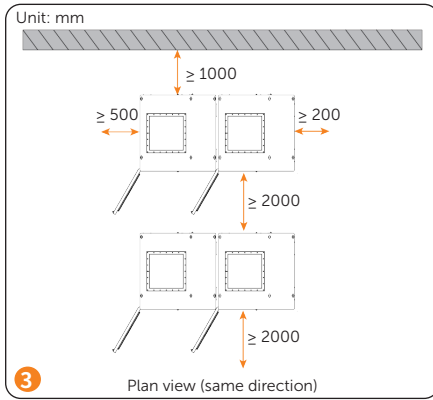

Figure 4-5 Clearance requirements for multiple cabinets (1)

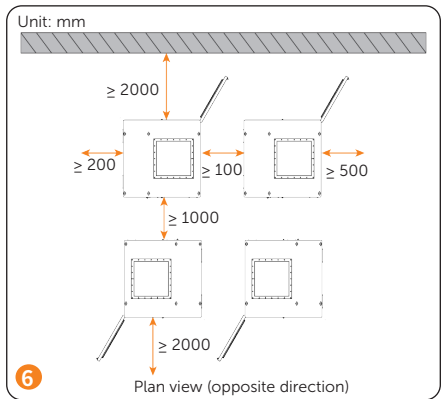
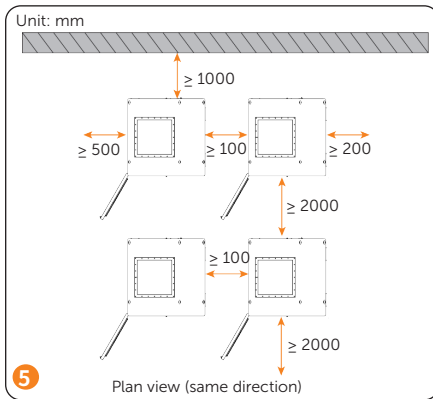
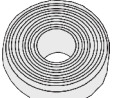

Figure 4-6 Clearance requirements for multiple cabinets (2)

## 4.2 Tool Requirements

The tools used include but are not limited to the recommended tools below. Please use other auxiliary tools according to the site requirements. Please note that the tools used must comply with local regulations.



 <p>Hammer drill (Ø18 mm)</p>	 <p>Multimeter (≥ 1500 d.c. V)</p>	 <p>Measuring tape</p>	 <p>Utility knife</p>
 <p>Marker</p>	 <p>Wire stripper</p>	 <p>Crimping tool for RJ45</p>	 <p>Wire cutter</p>
 <p>Hydraulic wire crimper</p>	 <p>Rubber mallet</p>	 <p>Torque wrench (M4–M12)</p>	 <p>Torque screwdriver (Flat head: M2) (Phillips head: M5, M6)</p>
 <p>Heat gun</p>	 <p>Heat shrink tubing (Ø15–20 mm) (Ø20–25 mm)</p>	 <p>Diagonal pliers</p>	 <p>Vacuum cleaner</p>
 <p>Crane</p>	 <p>Steel wire rope</p>	 <p>Cable tie</p>	 <p>Insulated ladder</p>
 <p>Electric forklift</p>	 <p>Safety vest</p>	 <p>Safety helmet</p>	 <p>Safety belt</p>

### 4.3 Additionally Required Materials

#### NOTICE!

- Select either grounding plate, or PE cable and ring terminal to ground the cabinet.
- If you use wire rather than grounding plate for cabinet grounding, prepare PE cable and ring terminal of corresponding specification.

Table 4-2 Additionally required materials

No.	Required Material	Type	Specification
1	Grid cable 	Five-core copper cable (L1, L2, L3, N wire: 70 mm <sup>2</sup> PE wire: 35 mm <sup>2</sup> )	Conductor cross-section: 70 mm <sup>2</sup> *4 + 35 mm <sup>2</sup> *1
2	Grounding plate 	Galvanized iron plate	Width: 40 mm Thickness: 4 mm
3	Ring terminal 	TLK35-12 ring terminal (Recommended)	 Inner diameter of cable conductor: TLK35-12: $\varnothing 8.5 \pm 0.3$ mm
4	PE cable 	Conventional yellow and green wire	Conductor cross-section: 16–35 mm <sup>2</sup>

# 5 Unpacking and Inspection

## 5.1 Unpacking

- The equipment undergoes 100% testing and inspection before shipping from the manufacturing facility. However, transport damage may still occur. Before unpacking the rechargeable battery, please verify that the model and outer packing materials for damage, such as holes and cracks.
- Due to the cabinet height exceeding 2 m, please take necessary precautions for working at heights when removing the outer packaging.

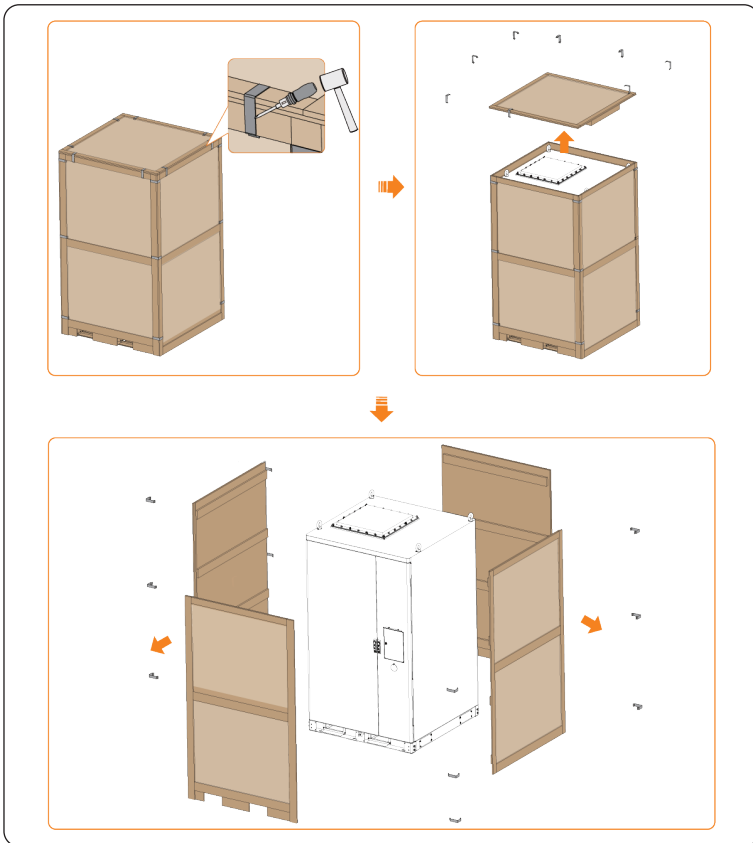

Figure 5-1 Unpacking

- When unpacking, please handle all packaging materials properly for future storage or relocation of this equipment.
- After unpacking, please check if the equipment is intact and if all accessories are complete. If there is any damage or missing accessories, please contact your dealer immediately for assistance.

## 5.2 Packing List

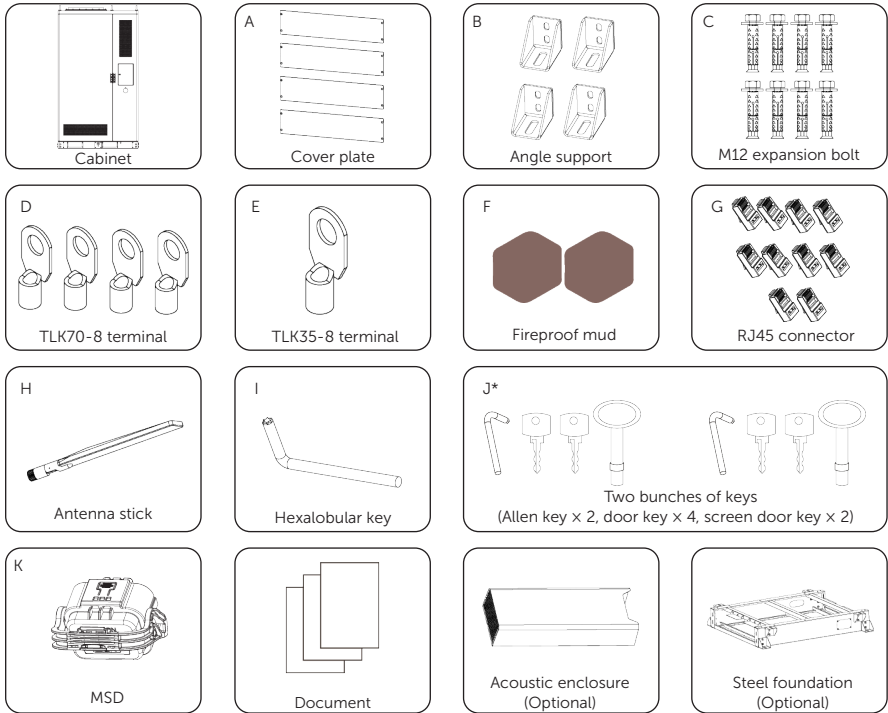

Table 5-1 Packing list

No.	Items	Quantity (PCS)	Description
/	Cabinet	1	/
A	Cover plate	4	For sealing the forklift blade inlet on the cabinet bottom
B	Angle support	4	For securing the cabinet

## Unpacking and Inspection

No.	Items	Quantity (PCS)	Description
C	M12*40 expansion bolt	8	For connecting the angle support and foundation
D	TLK70-8 terminal	4	For connecting the grid cables to the power distribution box inside the cabinet
E	TLK35-8 terminal	1	For connecting the PE wire of the grid cable to the cabinet
F	Fireproof mud	2	For sealing off the grid cable inlet
G	RJ45 connector	10	Reserved for communication or parallel connection
H	Antenna stick	1	For expanding data transmission
I	Hexalobular key	1	For assembling and disassembling the cover of the cabinet base
J*	Two bunches of keys	2	Each bunch includes 1 Allen key, 2 cabinet door keys, and 1 EMS screen door key
K	MSD	1	For personnel protection during maintenance
/	Document	/	/
/	Acoustic enclosure	Optional	/
/	Steel foundation	Optional	/

### NOTICE!

- The mark "\*" indicates that these keys are collected into a bunch.

# 6 Mechanical Installation

---

After determining the installation site, please take out the required underground cables.

## WARNING!

- Avoid installing, operating and maintaining the device or cables outdoors under severe weather conditions such as lightning, rain or snow.
- The device must be installed by professionals in accordance with local regulations and standards.
- Before drilling, please check and ensure that the area is free of pipes, light switches, sockets, and wires, and safe to drill into.
- Please wear PPE, and take steps to cover the device to prevent debris from entering it while drilling holes.
- After drilling, clean up the site in time.

## 6.1 Cabinet Handling

### NOTICE!

- There are two ways to move a cabinet: using a crane or a forklift. Please refer to ["3.1 Transportation Requirements"](#) for related handling precautions.

### 6.1.1 Crane Hoisting

#### NOTICE!

##### When hoisting:

- Temporary warning signs or fences should be set up in the hoisting area, and only the qualified persons can access it.
- Never stand and walk under or near the device being lifted or lowered.
- For safety reasons, avoid long-distance hoisting operations.
- Please be careful when hoisting and placing the device, and do not remove the ropes before it is seated on the foundation. Please make sure that the boom lift moves level and the cabinet's tilt angle is  $\leq 10^\circ$  during hoisting.
- The angle in both the diagonal ropes shall be  $\leq 60^\circ$ .
- Do not lift the next one before the previous cabinet has been installed on the foundation.

Check if the eye bolts are properly installed on the top of the cabinet, insert the steel wire ropes into the eye bolts, and then tie knots.

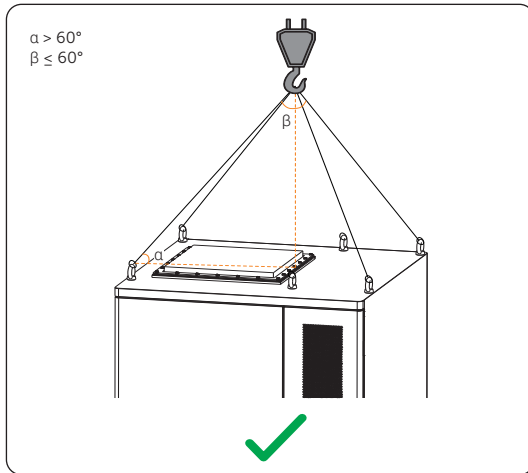

Figure 6-1 Proper way of hoisting

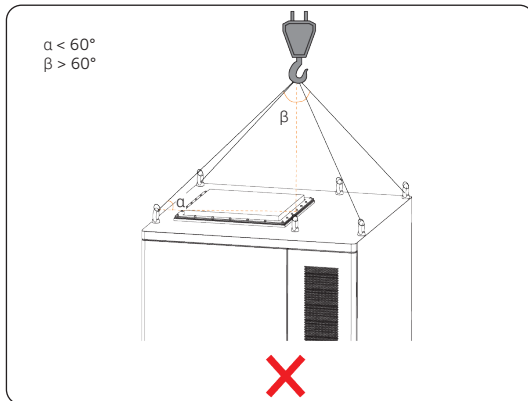

Figure 6-2 Improper way of hoisting

### 6.1.2 Forklift Handling

#### NOTICE!

- Before relocating the cabinet through a forklift truck, make sure you have secured the cabinet properly without any risks of tipping over.

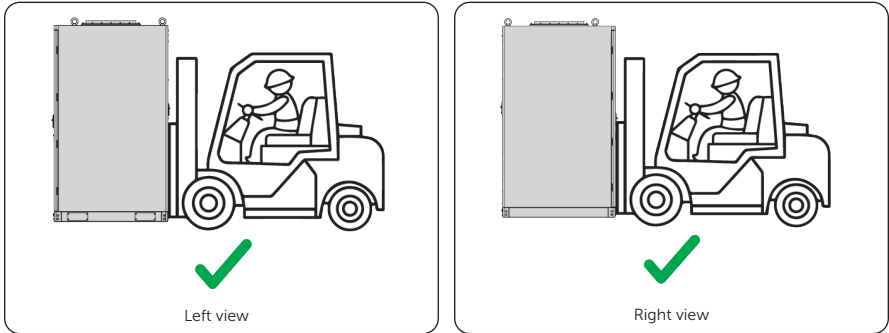

Figure 6-3 Proper way of handling

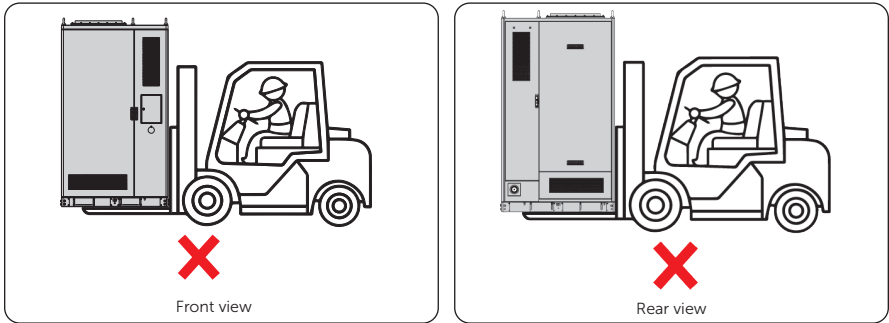

Figure 6-4 Improper way of handling

**NOTICE!**

- After unloading the cabinet from the forklift truck, check if there is any paint peeling or chipping. If there is, follow the instructions on "13.2 How to Repair the Cabinet" to repair.

## 6.2 Cabinet Fixing

The cabinet can be fixed simply through expansion bolts, or with angle supports.

### Fixing with Screws

**Step 1:** Draw four circles on the foundation surface based on the dimensions of the cabinet.

**Step 2:** Drill holes into the foundation through the circles, and then clean the site.

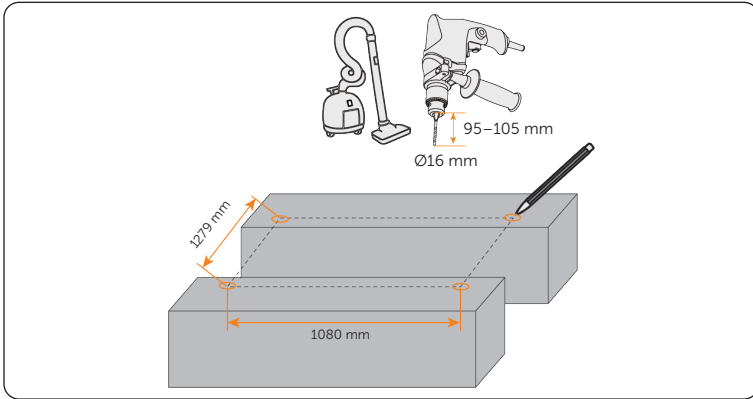

Figure 6-5 Drawing holes

- Step 3:** Use a crane or forklift to place the cabinet upright onto the foundation. Make sure the installation holes of the cabinet align with those of the foundation.
- Step 4:** Hammer in the expansion bolts, and then tighten it to secure the cabinet.

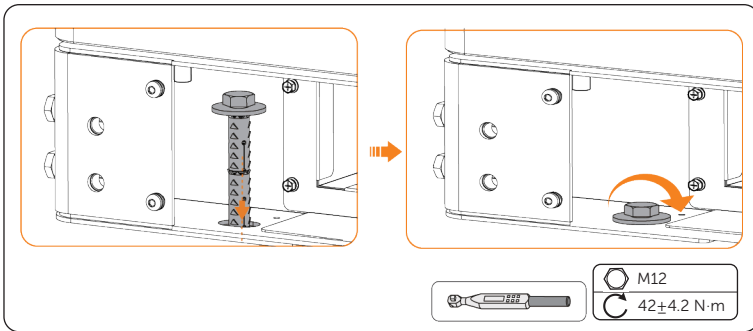

Figure 6-6 Securing the cabinet

- Step 5:** Remove the M6 screws attached to the cabinet, align the cover plates onto the cabinet, and then use the M6 screws to secure them.

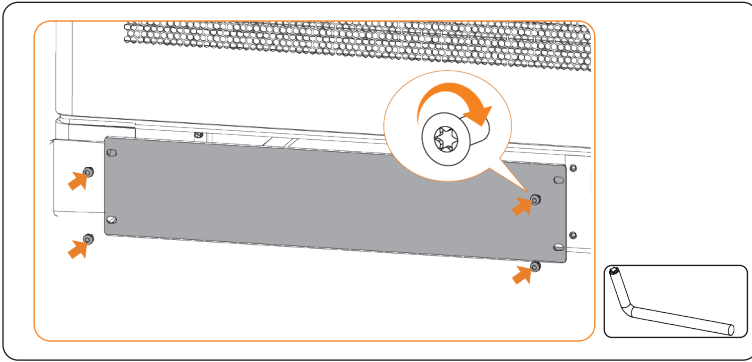

Figure 6-7 Fixing cover plate

### Fixing with Angle Supports

The cabinet allows the angle supports to be installed at the front and-rear sides or at the left and-right sides. The installation steps of all four angle supports at all sides are the same, and the following instructions use only one of them for example.

**Step 1:** Remove the M12 combination screws pre-fixed on the bottom of the cabinet.

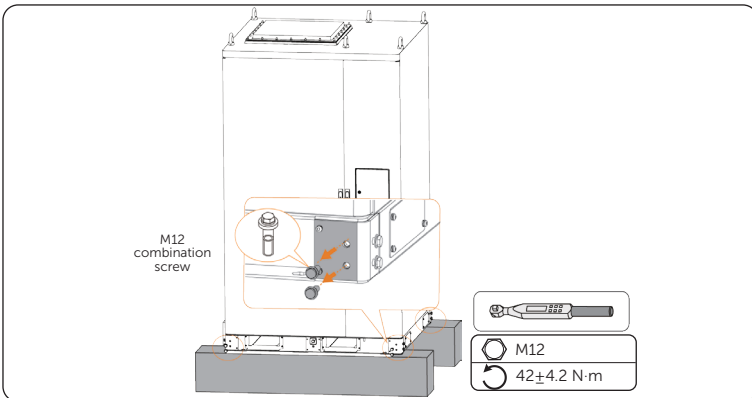

Figure 6-8 Removing M12 screws

**Step 2:** Align the installation holes of the angle support (part B) to those of the cabinet, and then draw circles on the foundation surface.

The distance between the center of the two circles shall be no less than 40 mm.

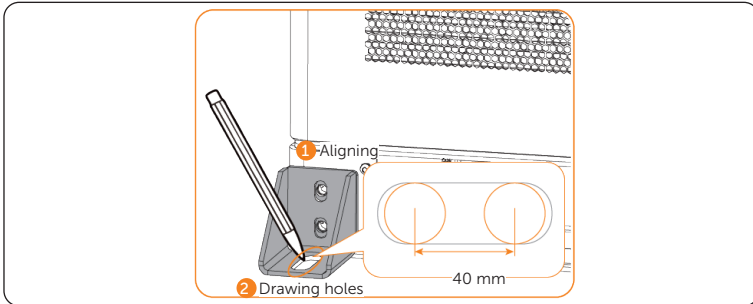

Figure 6-9 Aligning and drawing holes

**Step 3:** Drill holes through the marks, and then clean the site.

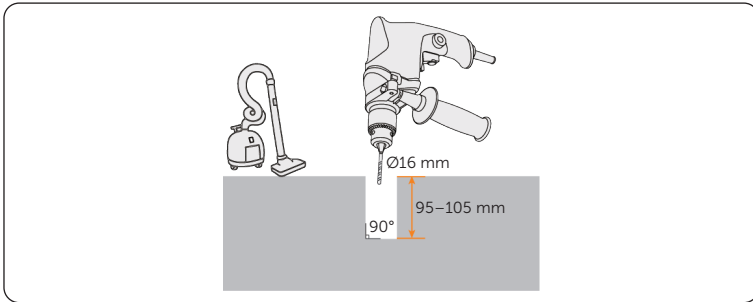

Figure 6-10 Drilling holes

**Step 4:** Reattach and fix the M12 combination screws to secure the angle support to the cabinet, and hammer in and fasten the M12 expansion bolts into the foundation to secure the cabinet to the foundation.

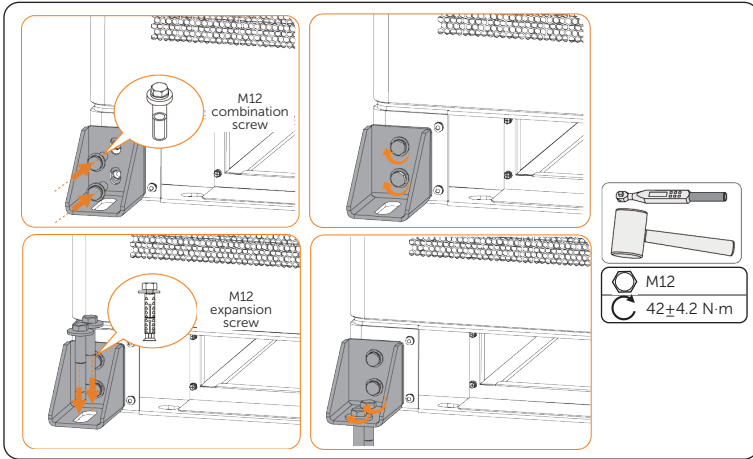

Figure 6-11 Securing the cabinet

**NOTICE!**

- If the angle supports are not secured, secure the cabinet through the hole A with the M12 expansion screws. See "Figure 2-4 Appearance and dimension (3)" for hole position.

**Step 5:** Remove the M6 screws pre-fixed on the cabinet next to the angle support installation position, attach the cover plate (part A), and then secure it with the M6 screws.

Follow the instruction to install altogether 4 cover plates at the front and rear sides of the cabinet bottom.

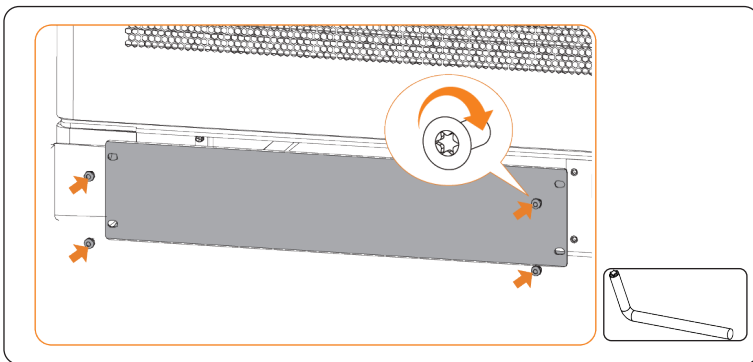

Figure 6-12 Fixing cover plate

### 6.3 Antenna Installation

The cabinet offers two antenna ports. The right one is for connecting the 4G antenna stick delivered with the cabinet, and the left one is reserved.

**NOTICE!**

- Keep the sealing caps on if the antenna terminals are not used.

**Step 1:** Remove the silicone cap.

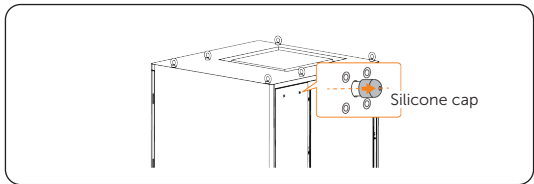

Figure 6-13 Removing silicone cap

**Step 2:** Insert and swirl the antenna stick (part H) clockwise to fix it on the cabinet port.

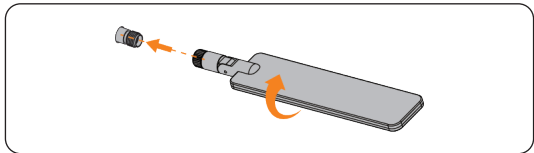

Figure 6-14 Installing antenna stick

**Step 3:** Fold the antenna up 90°.

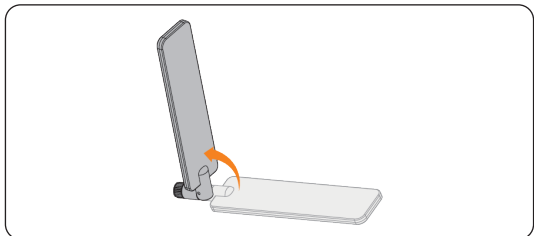

Figure 6-15 Folding up antenna stick

## 6.4 MSD Installation

Install the MSD connector in the accessory kit into the battery pack in the middle of the system.

**Step 1:** Remove the cover on the MSD socket of the battery pack.

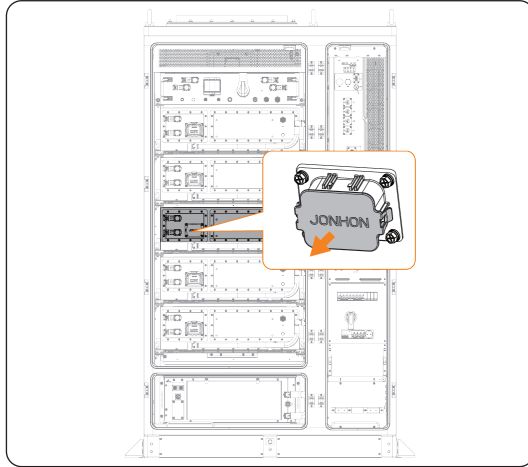

Figure 6-16 Removing MSD sokcet cover

**Step 2:** Install the MSD.

- a. » Insert the MSD into the MSD socket.
- b. » Push the handle up to make sure that the plug is fully closed.
- c. » Pull the green sheet to lock.

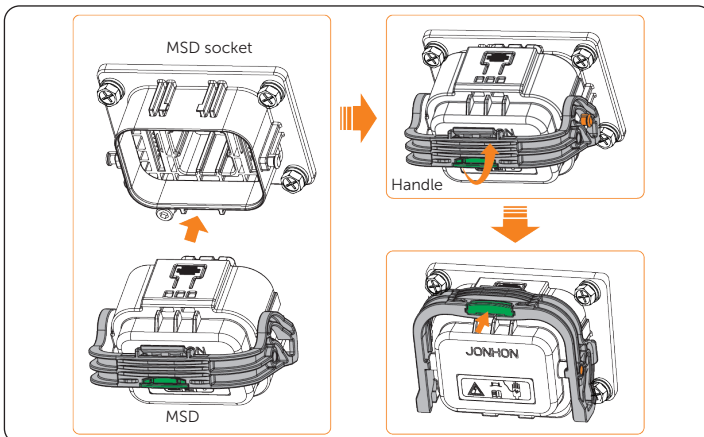

Figure 6-17 Installing MSD connector

## 6.5 Removal of Smoke Detector and Temperature Sensor Covers

Remove the dust-proof covers from the smoke detector and temperature sensor.

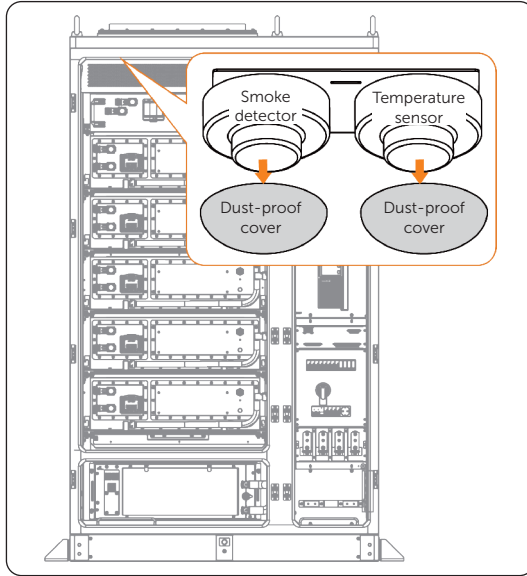

Figure 6-18 Removing dust-proof covers

# 7 Electrical Connection

The system features easy and convenient electrical connection. Most connections are already performed upon delivery, and users only need to connect the system to grid and ground for operation, or connect to more cabinets or other devices for varied functions.

Here are the positions of the wired parts.

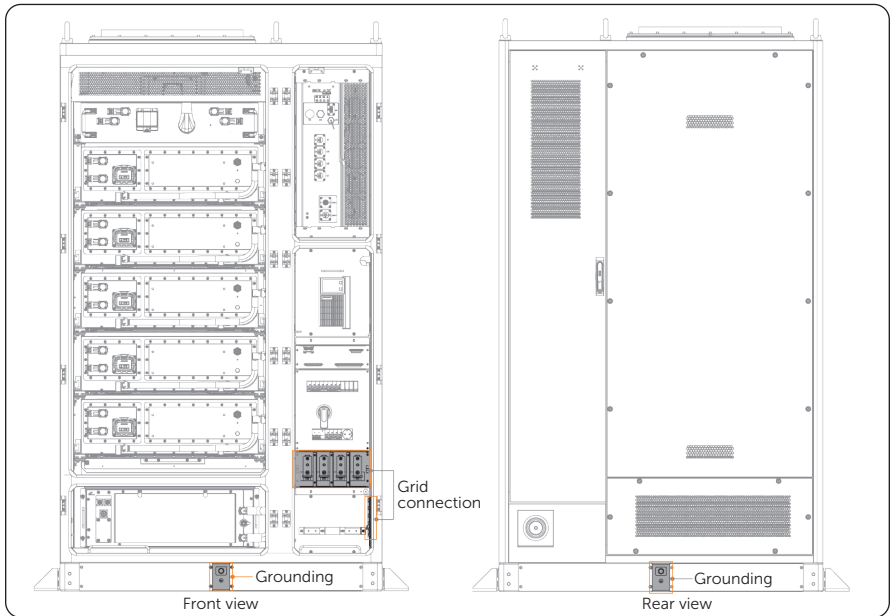

Figure 7-1 Position of the wired parts

## 7.1 Grounding Connection

Ground the cabinet through the grounding plate or PE wire.

### NOTICE!

- The cabinet offers 2 grounding terminals on the front and rear side. Select either terminal to perform grounding.
- The grounding plate, PE wire and ring terminal are not in the scope of delivery. Please prepare them in advance according to "4.3 Additionally Required Materials".

### Grounding Plate Connection

**Step 1:** Remove the M12 combination screw from the grounding terminal.

**Step 2:** Align the grounding plate to the grounding terminal, and then secure them using the M12 screw.

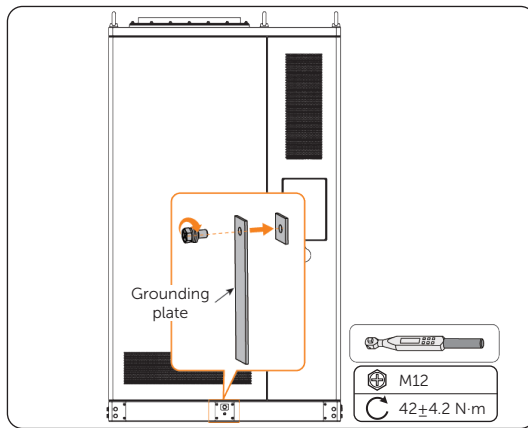

Figure 7-2 Securing grounding plate

### PE Wire Connection

**Step 1:** Remove the M12 combination screw from the grounding terminal.

**Step 2:** Strip the outer jacket off the PE cable to an appropriate length.

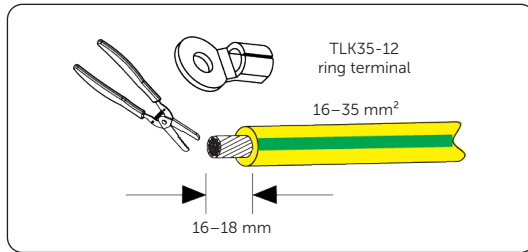

Figure 7-3 Stripping cable jacket

- Step 3:** Cut a section of heat shrink tubing, thread it through the stripped cable, and then attach the ring terminal.

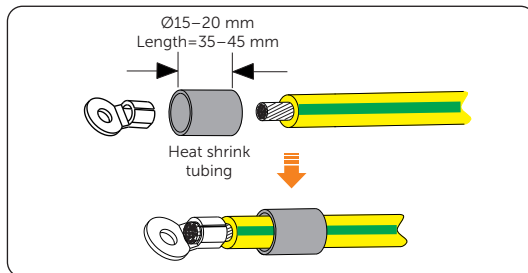

Figure 7-4 Attaching tubing and ring terminal

- Step 4:** Crimp the terminal, pull the heat shrink tubing to the crimped area, and then heat them with a heat gun.

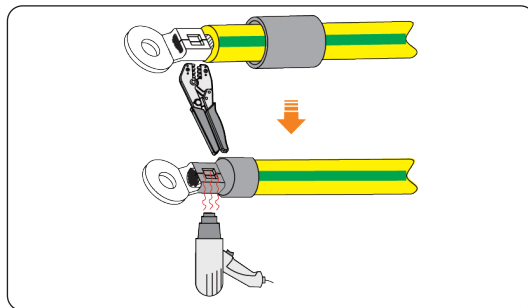

Figure 7-5 Crimping and heating

- Step 5:** Align the ring terminal of the PE cable to the grounding terminal, and then secure them using the M12 screw.

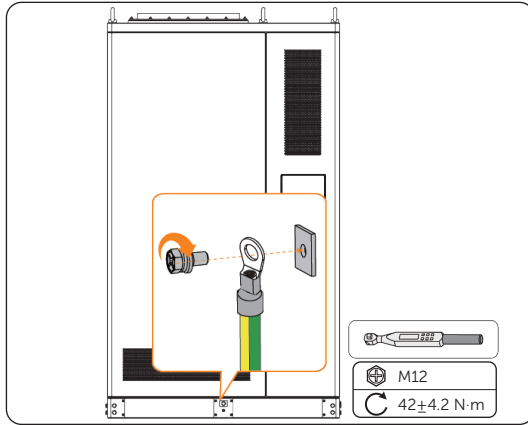

Figure 7-6 Securing PE cable

## 7.2 Grid Connection

### NOTICE!

- Take out the underground electrical wiring which is buried beneath the ground.
- Regarding the terminal requirements, please refer to "14.1 Requirements for OT/DT/TO Terminal".

**Step 1:** Remove the cover for the cable threading hole on the right side of the cabinet bottom.

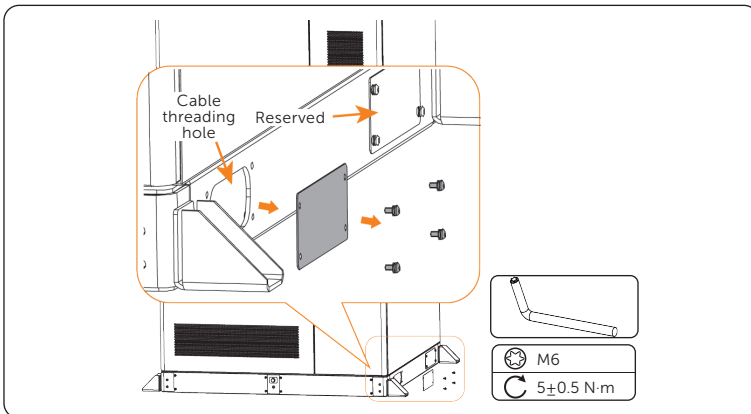

Figure 7-7 Removing the cover for cable threading hole

## NOTICE!

- Two cable threading holes are available. Use the front hole to thread the grid cables.

**Step 2:** Use the hexalobular key (part I) and the key for the cabinet door (part L\*) to unlock the front door at the right side.

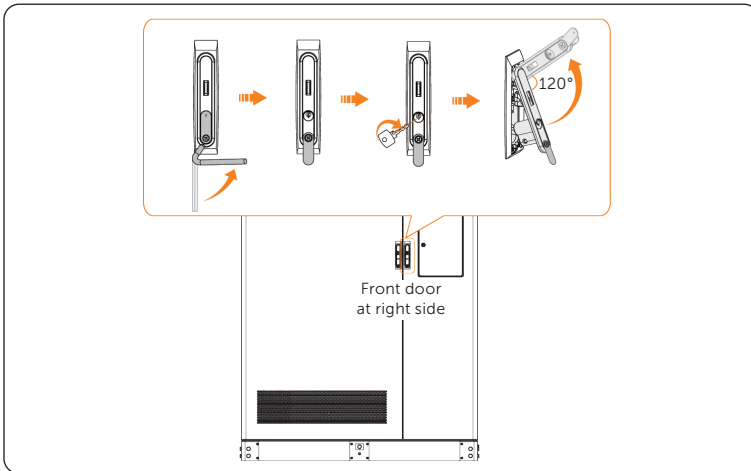

Figure 7-8 Unlocking the front door

**Step 3:** Place the limiting rod at an appropriate position to keep the door open. This can protect the door coating against damages caused by the hinge.

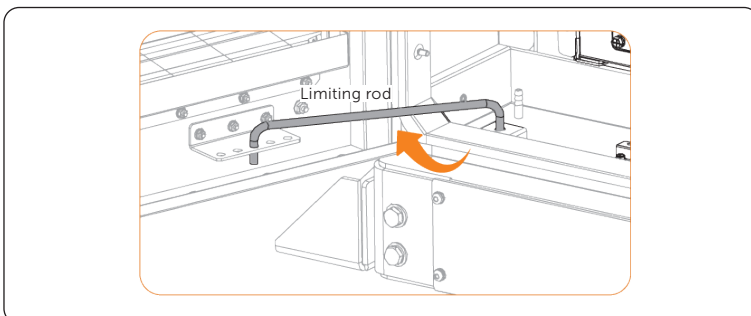

Figure 7-9 Placing the limiting rod

**Step 4:** Remove the cover for voltage cables from the distribution box.

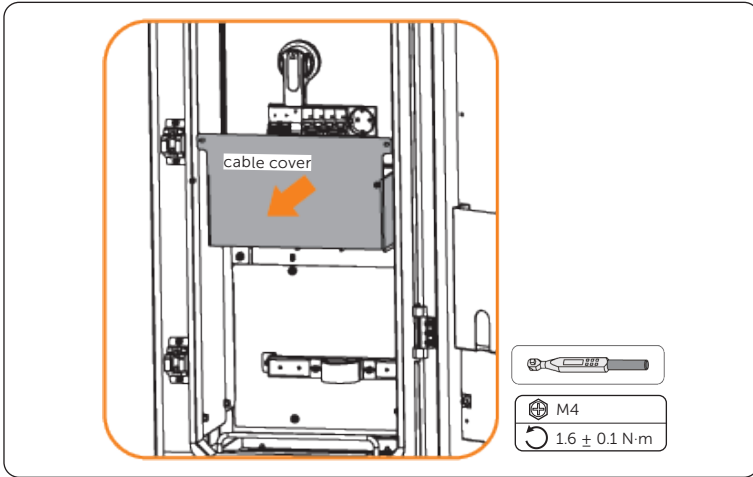

Figure 7-10 Removing cable cover

**Step 5:** Unscrew the M8 screws from the copper terminal plate of the distribution box for securing voltage cables, and then unscrew an M8 screw from the earth bar.

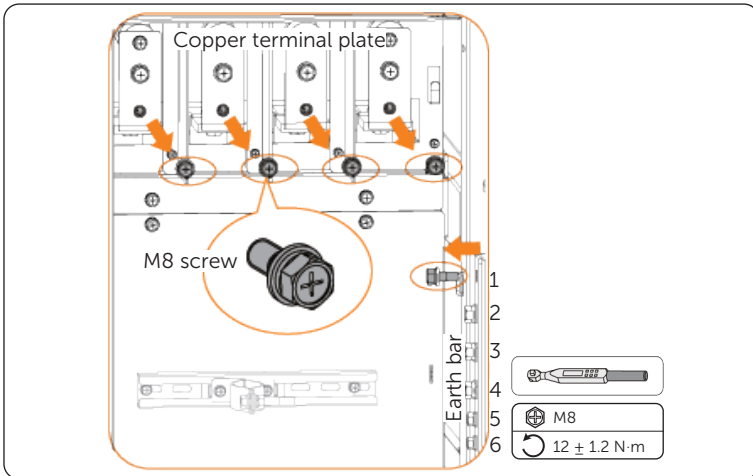

Figure 7-11 Unscrewing screws

**NOTICE!**

- Unscrew the screw on terminal 1 from top to bottom for PE wire.

**Step 6:** Unscrew the M6 combination screw on the cable clamp, and then slide the clamp apart to both sides on the rail.

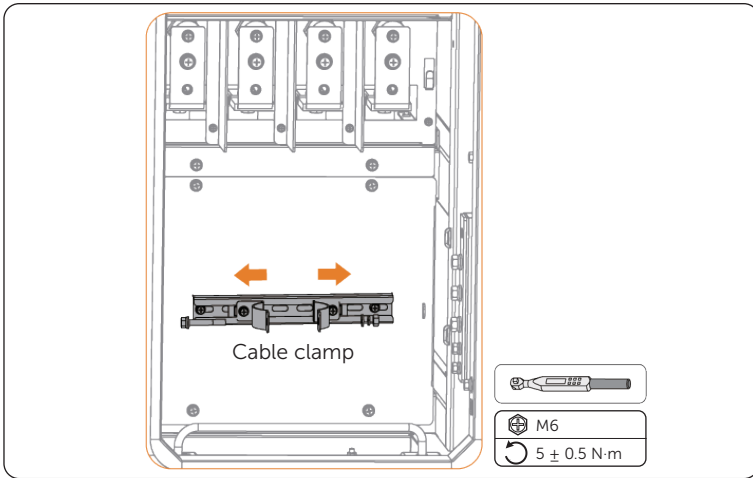

Figure 7-12 Removing cable clamp

**Step 7:** Remove the assembled fireproof mud panel from the cabinet, and then disassemble them into 3 parts.

**NOTICE!**

- Only the M5 screws and the cover plate will be reused.

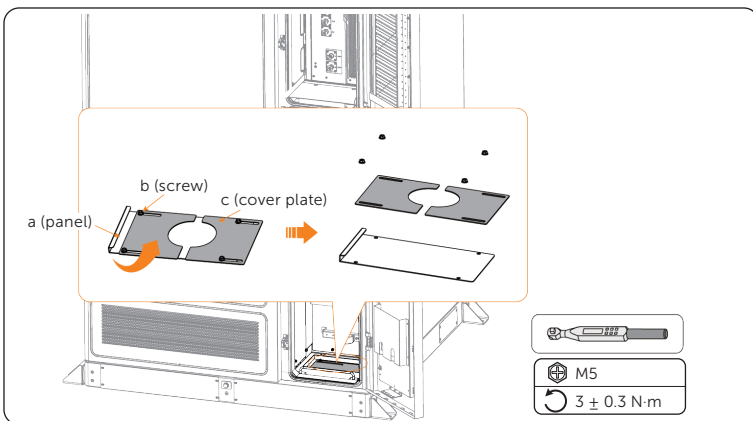

Figure 7-13 Removing fireproof mud panel

**Step 8:** Make the grid cable.

**NOTICE!**

- We recommend conducting a health check for the grid cable before stripping it.
- Use controlled motion to strip the jacket and insulation layer to prevent damages on the wires.
- Make sure that the insulation layer has been stripped to a sufficient length so that the conductor is fully exposed without any damage or nicks. In addition, make sure that no extra insulation remains beyond the connector once it's crimped on.

- a. Stripe the outer jacket and insulation layer off the grid cable to an appropriate length.

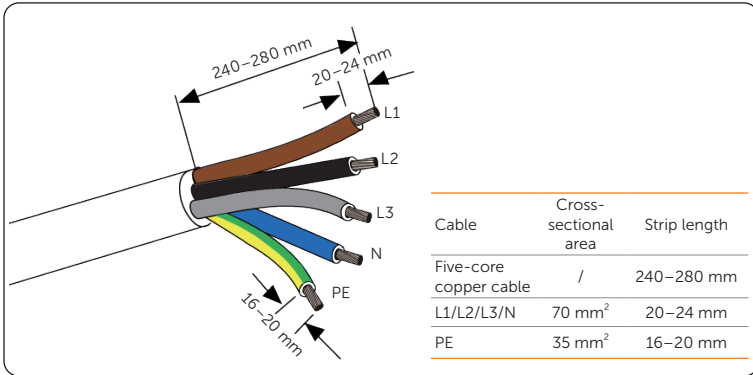

Figure 7-14 Striping wires

- b. Cut sections of heat shrink tubing, thread them through the stripped wires, and then attach the ring terminals.

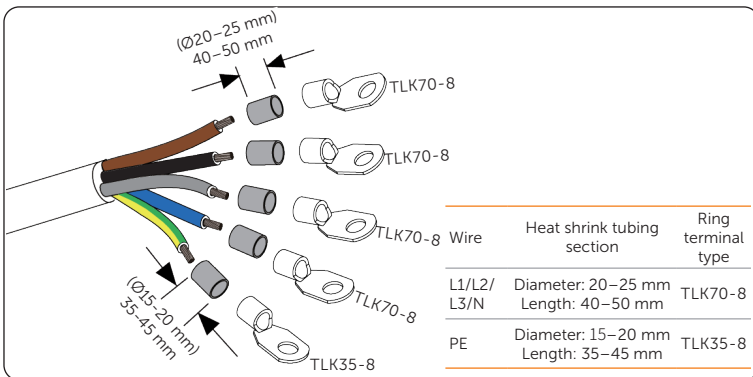

Figure 7-15 Attaching tubing and ting terminals

- c. Crimp the ring terminals, pull the heat shrink tubings to the crimped area, and then heat them with a heat gun.

**NOTICE!**

- Do not damage the conductor insulation while crimping.
- Do not place the conductor insulation into the terminal.
- Move the heat gun back and forth slowly to distribute the heat evenly across the surface of heat shrink tubing.

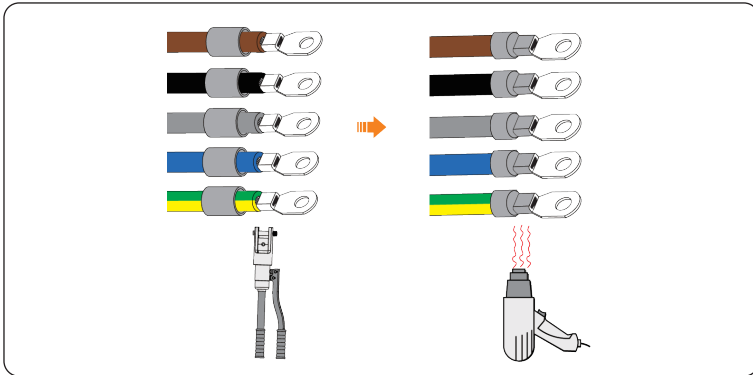

Figure 7-16 Crimping and heating the wires

- Step 9:** Thread the grid cable through the cable threading hole at the right side of the cabinet, and then through the cable hole on the bottom.

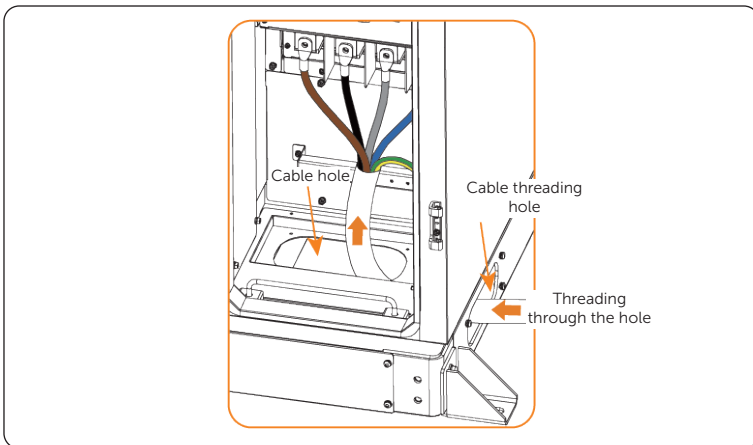

Figure 7-17 Threading the cable

**Step 10:** Slide the cable clamps on the rail towards the cable, and then attach the original M6 screw on the cable clamp.

Attach but do not tighten the M6 screw in case you need to adjust the grid cable.

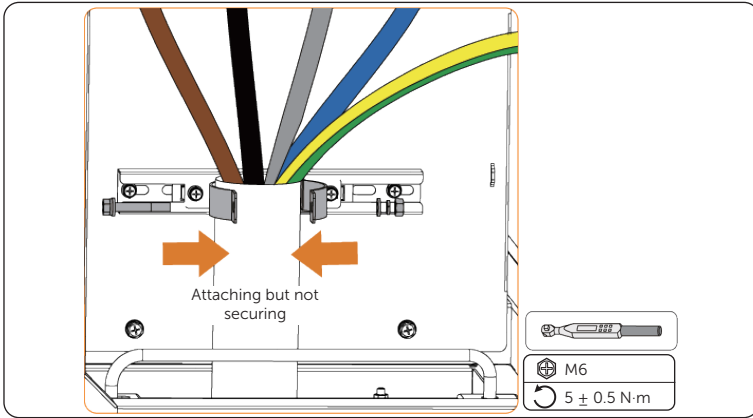

Figure 7-18 Reattaching the cable clamp

**Step 11:** Align the voltage wires to the terminals of the copper terminal plate based on the markings, and align the PE wire to the earth bar, and then use the M8 screws to secure them.

**NOTICE!**

- Connect the PE wire through terminal 1 on the PE bar.

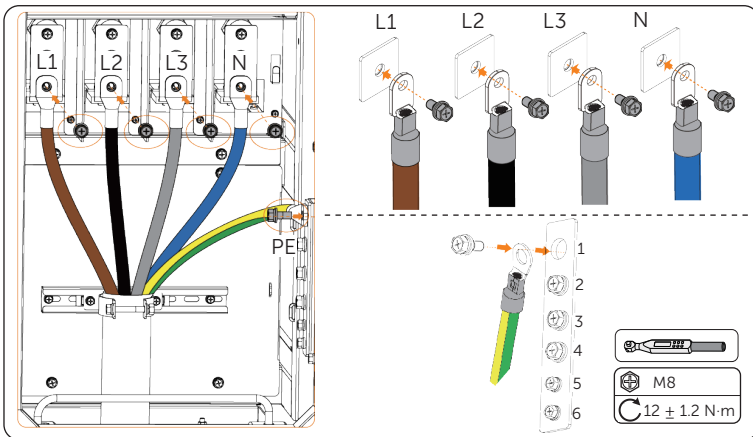

Figure 7-19 Securing grid wires

**Step 12:** Tighten the screw for the cable clamp, and then attach and secure the wire cable for the grid wires with the original M5 screws.

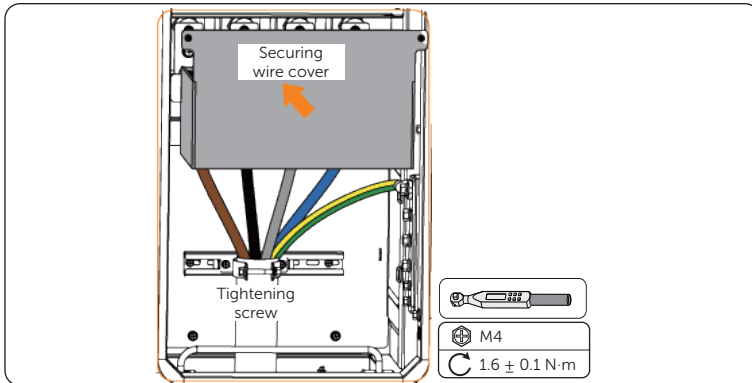

Figure 7-20 Securing cable clamp and wire cover

**Step 13:** Assemble the M5 screw and cover plate, reinstall it onto the cabinet, and then seal the cover plate hole with fireproof mud.

### NOTICE!

#### Notice for fireproofing mud:

- Take out the fireproof mud delivered with the cabinet and knead it into a ball shape. In the case of the low temperature, place it into warm water, of which the temperature range is between 40°C and 70 °C, with its package until it is soft.
- Clean the area around the cable threading hole before sealing it.
- The fireproof mud should be evenly spread, embedded, or filled in the cable threading hole. If such a hole is too large, a fireproofing board can be placed to enhance fire protection before using the mud.
- The fireproof mud needs to be cured after sealing the cable threading hole. Prevent water from entering and colliding during curing.

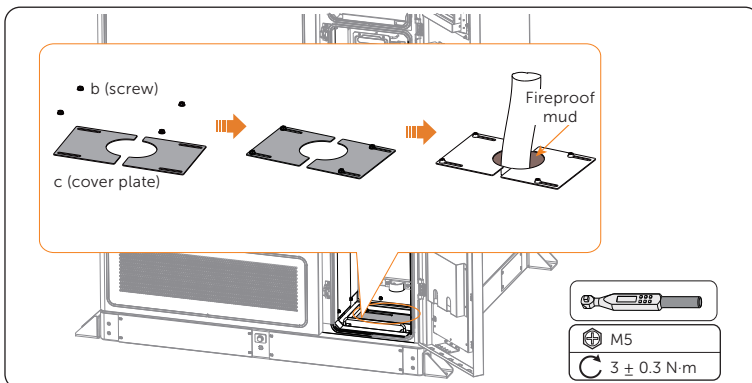

Figure 7-21 Sealing the cable hole

## 7.3 Communication Connection

### 7.3.1 Network Connection

Connect EMS to Ethernet so that you can view the system operation details remotely.

#### NOTICE!

- Network cable is not in the scope of delivery. Please prepare them in advance.

**Step 1:** Strip the outer jacket off the network cable to an appropriate length at both ends.

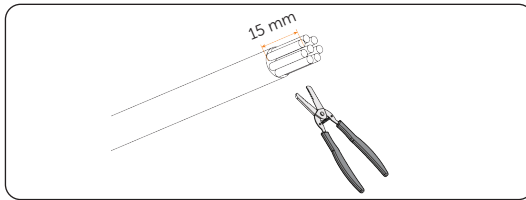

Figure 7-22 Stripping cable jacket

**Step 2:** Insert the wires into the pin contacts of the RJ45 connector (part G) in sequence, and then use a crimping tool to securely crimp the wires into the connector.

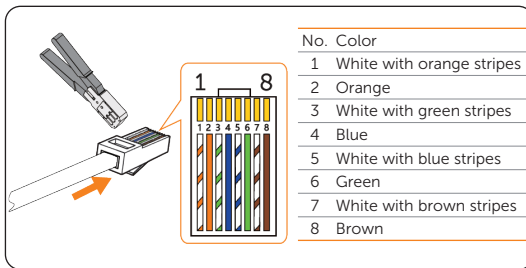

Figure 7-23 Crimping RJ45

**Step 3:** Use the hexalobular key (part I) and the key for the cabinet door (part L\*) to unlock the front door at the right side.

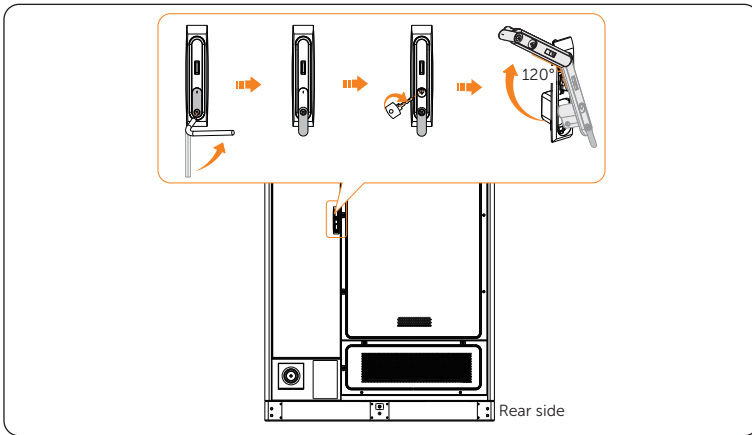

Figure 7-24 Opening the rear door

- Step 4:** Place the limiting rod at an appropriate position to keep the door open. This can protect the door coating against damages caused by the hinge.

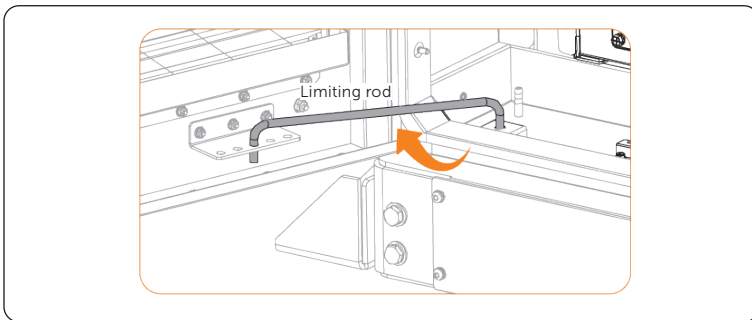

Figure 7-25 Opening the rear door

- Step 5:** Cut open the seal of the cable threading hole on the bottom of the cabinet .

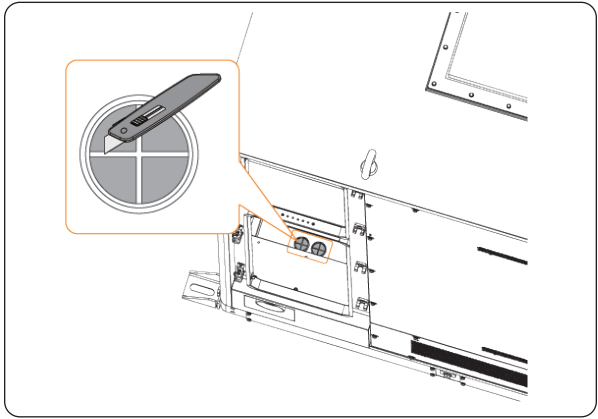
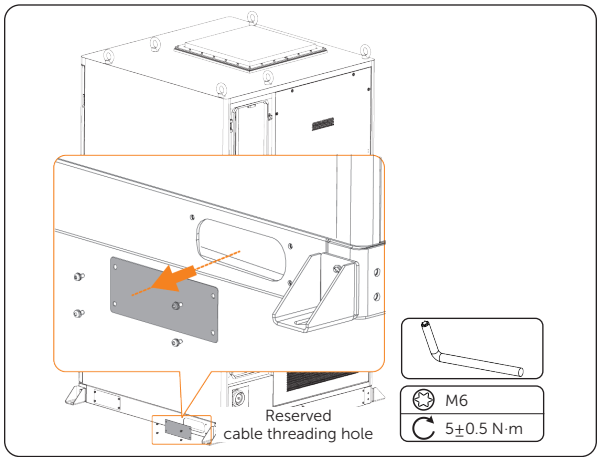

Figure 7-26 Cutting open the seal of cable hole

**Step 6:** Remove the cover from the reserved cable threading hole next to the rear door.



**Step 7:** Thread one end of the network cable through the reserved cable hole and cable threading hole in sequence.

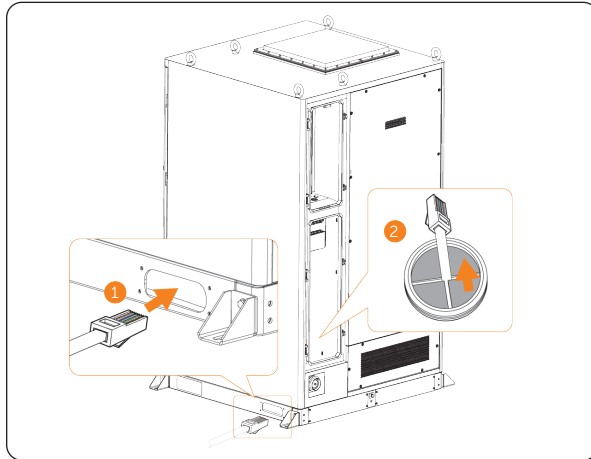

Figure 7-27 Threading through the network cable

**Step 8:** Insert one end of the network cable connector into NET4 of EMS, and the other end of the cable to the router or switch.

A click sound will be heard when the connector is properly inserted into the port.

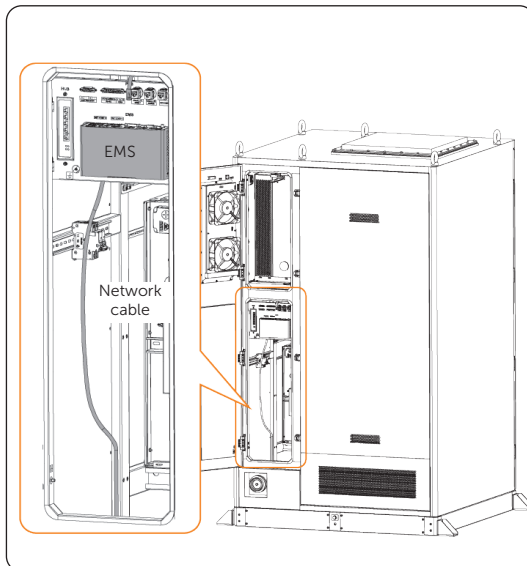

Figure 7-28 Running the Ethernet cable

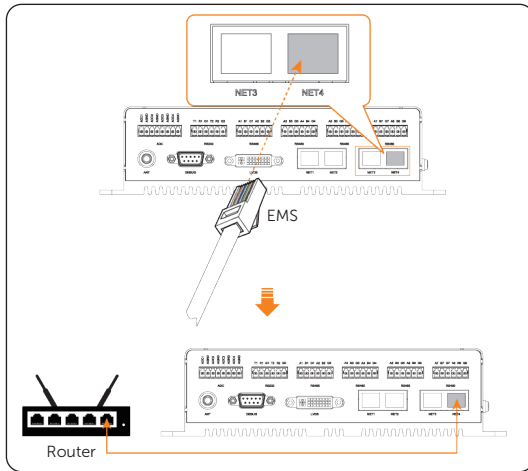

Figure 7-29 Connecting the network to EMS and switch

### 7.3.2 Meter Connection

Connect the meter to EMS1000 of the cabinet.

**NOTICE!**

- DTSU666 is used for wiring procedure illustration.
- This meter model includes a communication cable upon delivery.

Table 7-1 Corresponding terminals of EMS1000 and DTSU666

RS485 terminal of EMS1000		RS485 terminal of DTSU666	
Marking	Pin assignment	Marking	Pin assignment
RS485-A8	RS485A	24	RS485A
RS485-B8	RS485B	25	RS485B

**Step 1:** Strip the communication cable to an appropriate length at both ends.

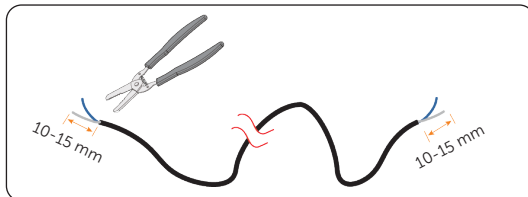

Figure 7-30 Stripping the communication cable

**Step 2:** Use a flat-headed screwdriver to secure the conductors into A8 and B8 of the RS485 terminals.

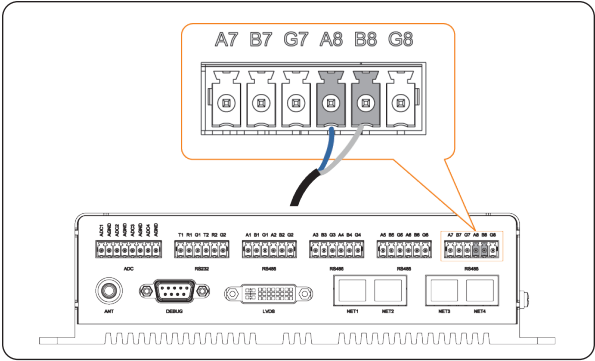

Figure 7-31 Connecting communication cable to EMS1000

**Step 3:** Thread the other end of the communication out of the cabinet through the cable threading holes, and then connect the other end of the conductors respectively into port 24 and 25 of the meter.

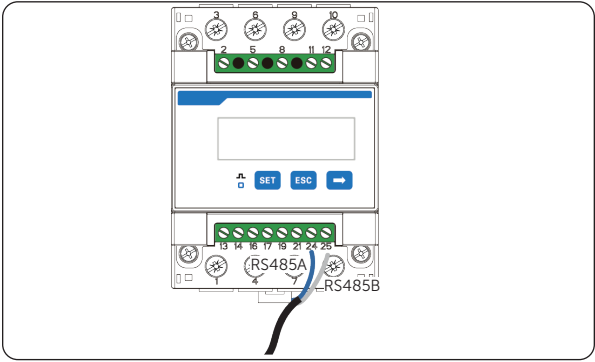

Figure 7-32 Connecting communication cable to meter

# 8 System Power-on

---

## 8.1 Checking before Power-on

Ensure that all the cables are properly connected, and that all the electric components are switched off.

Table 8-1 Checklist

No.	Item	Description
1	Equipment appearance	<ul style="list-style-type: none"><li>• Check whether the equipment is in good condition, with a clean, non-peeling paint, and rust-free surface.</li><li>• Ensure that the labels on the equipment are clear and easy to read. If it is damaged, the label shall be replaced at once.</li></ul>
2	Cable appearance	<ul style="list-style-type: none"><li>• Check whether the cable jacket is in good condition.</li><li>• Check whether the protective pipes are in good condition.</li></ul>
3	Cable connection	<ul style="list-style-type: none"><li>• Check whether the cable connection position is consistent with the design principles.</li><li>• Ensure that the procedure for crimping terminals strictly observe the requirements, and the terminals are securely fastened.</li><li>• Check whether the labels on the both sides of cables are clear, and the direction of both labels is the same.</li></ul>
4	Wiring	<ul style="list-style-type: none"><li>• Ensure that the wiring procedure is consistent with the principle of separation of strong and weak electricity.</li><li>• Ensure that the cables are neatly places.</li><li>• Leave a little extra length for adjustments.</li><li>• Keep cables tidy in the cabinet.</li><li>• <b>Check if the grid connection voltage meets: L1+N=220/230 V, L2+N=220/230 V, L3+N=220/230V, L1+L2=380/400 V, L2+L3=380/400 V, L1+L3=380/400 V.</b></li></ul>
5	Copper bars in the battery pack	Check to make sure the copper bars are not deformed.
6	Button/Switch	<ul style="list-style-type: none"><li>• Check the distribution box's switch is "OFF".</li><li>• Check the battery packs' switches are "OFF".</li></ul>
7	Liquid cooling pipe	Check if the liquid cooling pipes are properly installed and secured.

## 8.2 Powering on the System

The position of components for powering on the system are as follows.

### NOTICE!

- Each time after turning on a component of the cabinet system, make sure the component works normally.

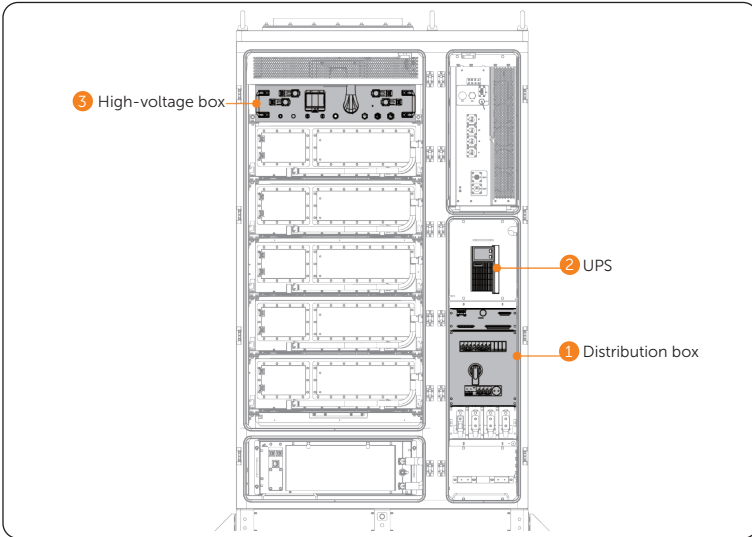

Figure 8-1 Position of modules for powering on system

**Step 1:** Start the distribution box.

- Rotate the switch on the distribution box to the "ON" position;

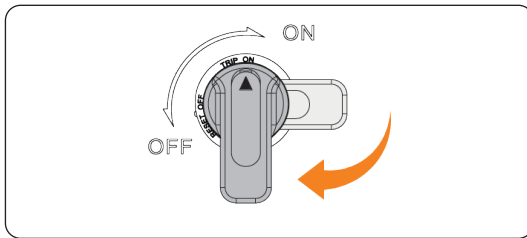

Figure 8-2 Switching on the distribution box

- Flip up the "APS1" breaker";
- Flip up the "SPD MCB" breaker;

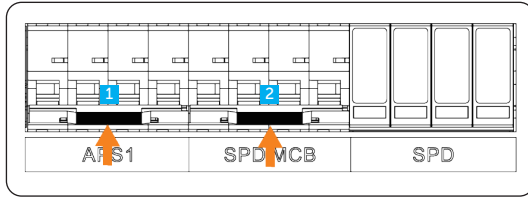

Figure 8-3 Flipping up breakers on distribution box (1)

- d. Flip up the "Cooling System MCB" breaker;
- e. Flip up the "UPS" breaker;
- f. Flip up the "APS2" breaker.

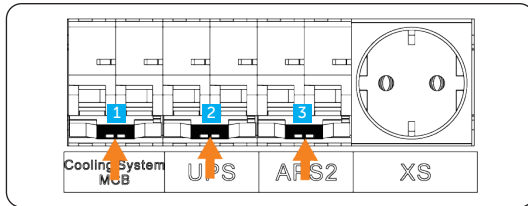

Figure 8-4 Flipping up breakers on distribution box (2)

**Step 2:** Press and hold the power button of the UPS for 3 seconds to turn on it.

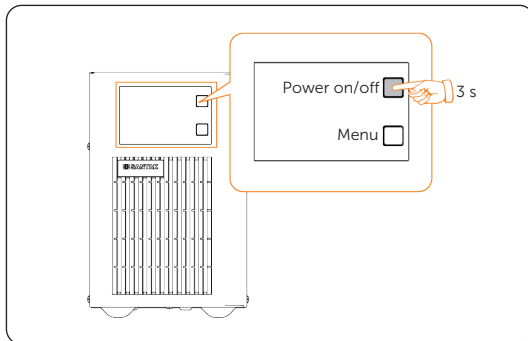

Figure 8-5 Holding and pressing button

**Step 3:** Start the high-voltage box.

- a. Flip up the breakers of the high-voltage box.

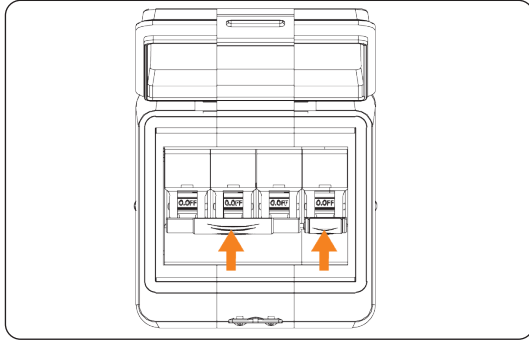

Figure 8-6 Flip up breakers on high-voltage box

- b. Rotate the switch to the "ON" position.

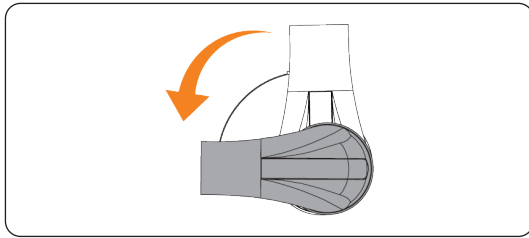

Figure 8-7 Switching on the high-voltage box

**Step 4:** Close the front doors, and remove and properly keep the keys.

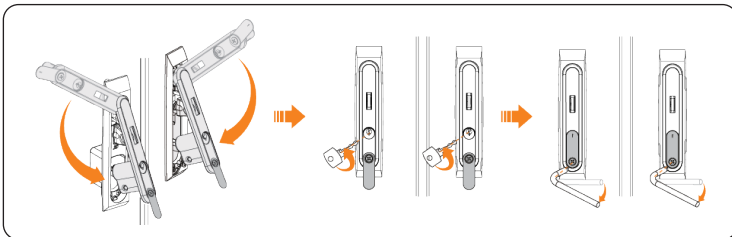

Figure 8-8 Closing the front doors

**NOTICE!**

- Make sure you have locked the doors well after normally powering on the system.

# 9 Operation on EMS and SolaXCloud

Log in to EMS and SolaXCloud for unified management of the system. You can log in to EMS through local screen on the cabinet or EMS webpage, and log in to SolaXCloud for cloud related operations.

## 9.1 EMS Screen Login

**Step 1:** Gently and correctly guide the key into the keyhole, and then turn it clockwise to unlock the screen door.

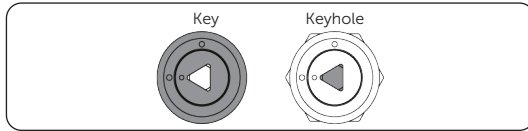

Figure 9-1 Correct position

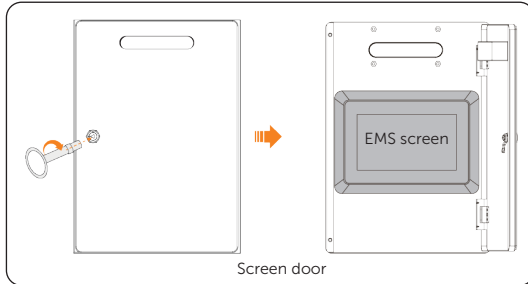

Figure 9-2 Unlocking screen door

**Step 2:** On the login screen, enter the username and password of the admin account, and then tap **Login**.

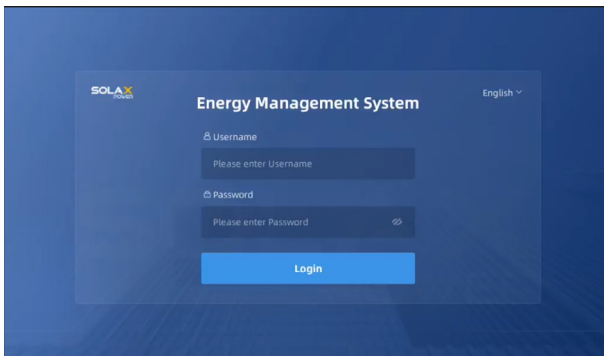

Figure 9-3 Logging in to the screen

NOTICE

Account information for logging in to EMS:

Username	Initial Password
user	123456

EMS SN

Username	Password
user	123456 by default

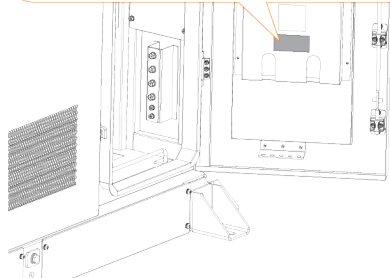

Position of EMS SN label

NOTICE!

- Scan the SN QR code of EMS on the label pasted on the bottom of the cabinet door interior, or log in to EMS through the user account, and then go to **Data > EMS > EMS Registration No.** to obtain the SN.

Figure 9-4 Positon of EMS SN label

## 9.2 SolaXCloud APP Login

**Step 1:** Download and install the App.

Select and scan the QR code below to download SolaxCloud APP. You can also find the QR codes at the button right of the login page of [www.solaxcloud.com](http://www.solaxcloud.com). In addition, you can search with the key word SolaxCloud in Apple Store or app store to download it.



Figure 9-5 QR code

**Step 2:** On the login page, enter your username and password. Select the checkbox to agree to the privacy policy and terms of use. Click on **Log in** to complete the app login. You can directly contact the SolaX to obtain your login credentials.

**Welcome!**



Remember me [Forgot password?](#)

Log in means that you have read, understood and agreed to the [Privacy Policy](#) and [Terms of Use](#)

Figure 9-6 Login page

# 10 Troubleshooting and Maintenance

## 10.1 Powering off the System

There are two methods to power off the system: normal power-off and emergency power-off. The latter is used only in emergencies.

### Normal Power Off

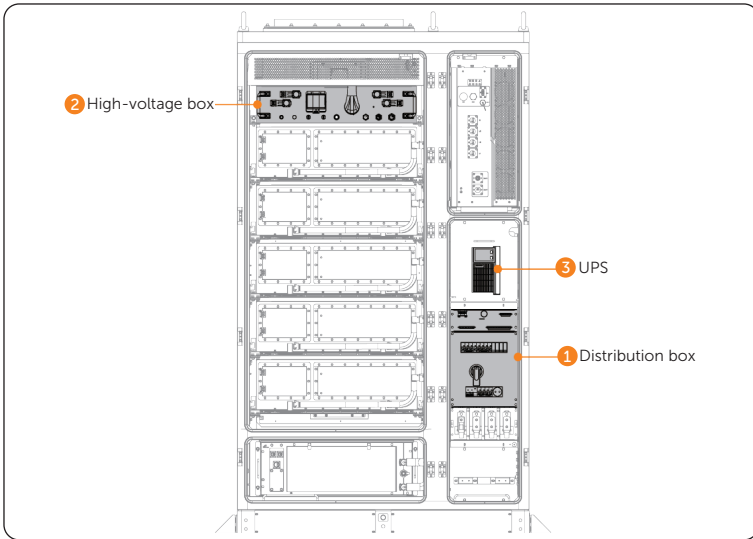

Figure 10-1 Position of modules for normally powering off system

**Step 1:** Open the front doors.

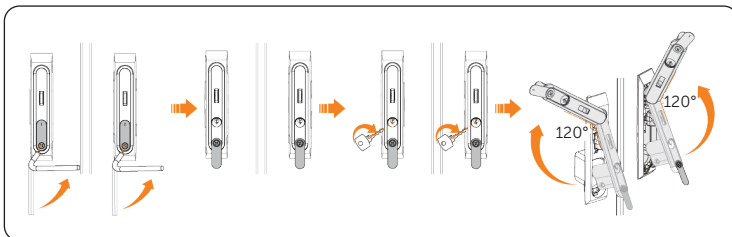

Figure 10-2 Opening the front doors

**Step 2:** Shut down the distribution box.

- a. Flip down the "Cooling System MCB" breaker;
- b. Flip down the "UPS" breaker;
- c. Flip down the "APS2" breaker.

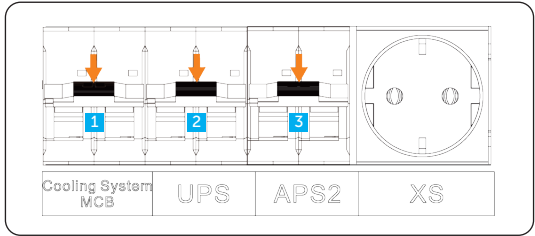

Figure 10-3 Shutting down breakers on distribution box (1)

- d. Flip down the "APS1" breaker;
- e. Flip down the "SPD MCB" breaker;

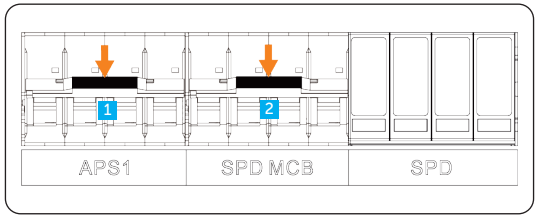

Figure 10-4 Flipping down breakers on distribution box (2)

- f. Rotate the switch on the distribution box to "OFF" position;

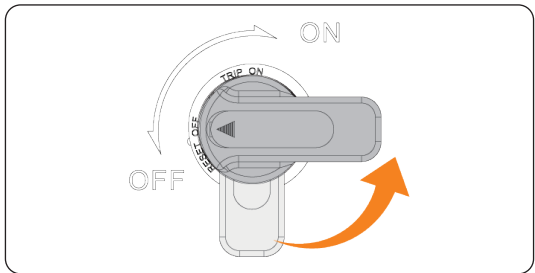

Figure 10-5 Switching off the distribution box

**Step 3:** Shut down the high-voltage box.

**WARNING!**

- Before switching off the high voltage box, check the LED indicator light status of the high voltage box. If it is flashing green, do not operate it in case of load breaking.

- a. Rotate the switch on the high-voltage box to "OFF" position.

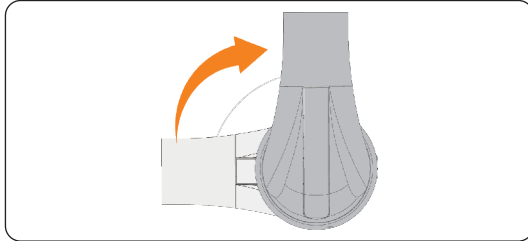

Figure 10-6 Switching off the high-voltage box

- b. Flip down the breakers on the high-voltage box.

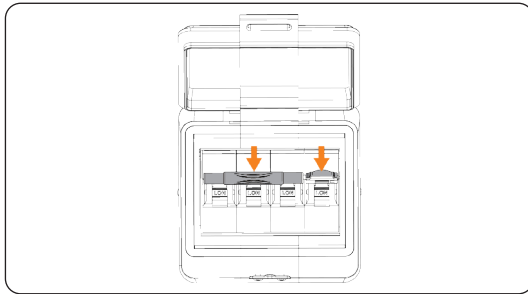

Figure 10-7 Flipping down high-voltage box breakers

**Step 4:** Press and hold the power button of the UPS for 3 seconds to shut down it.

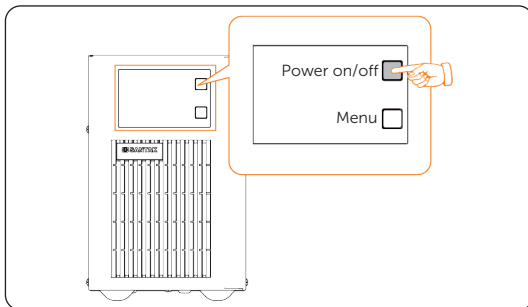

Figure 10-8 Shutting down the UPS

## Emergency Power Off

### ! WARNING!

- Do not press the emergency stop button unless in an emergency.
- Some modules inside the cabinet may still have power after pressing the emergency stop button, therefore, non-professionals are not allowed to operate them.

**Step 1:** Flip up the cover.

**Step 2:** Press the emergency stop button.

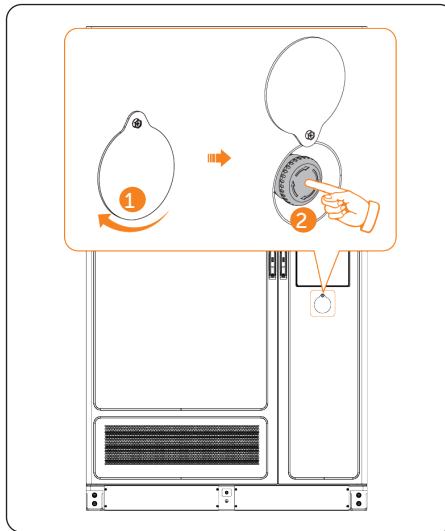

Figure 10-9 Pressing emergency stop button

### NOTICE!

**If it has been pressed, the emergency stop button must be reset before starting the equipment. The reset steps are shown as follows:**

- a. Rotate the cover;
- b. Rotate the button according to the arrow direction shown on the button. Then the button will spring back to its original position.

## 10.2 Troubleshooting

This section lists the possible problems with the equipment, and provides information and procedures for identifying and resolving them. In case of any errors, check for the warnings or error messages on the system control panel or App, and then refer to the suggestions below. For further assistance, contact SolaX Customer Service. Please provide the model and SN of the cabinet, and be prepared to describe the system installation details.

Table 10-1 Troubleshooting list

Fault code	Description and Diagnosis
UCellHi_4	<p>Single Cell Overvoltage Category IV</p> <ul style="list-style-type: none"> <li>Do not power on, and the charging current is limited to 0 A. If the relay does not receive a power-off instruction from the PCS, it will be turned off forcefully after 3 seconds.</li> <li>Or contact SolaX for help.</li> </ul>
UCellHi_5	<p>Single Cell Overvoltage Category V</p> <ul style="list-style-type: none"> <li>Do not power on, and the charging current is limited to 0 A. If the relay does not receive a power-off instruction from the PCS, it will be turned off forcefully after 1 second.</li> <li>Or contact SolaX for help.</li> </ul>
UCellLow_4	<p>Single Cell Undervoltage Category IV</p> <ul style="list-style-type: none"> <li>Do not power on, and the charging current is limited to 0 A. If the relay does not receive a power-off instruction from the PCS, it will be turned off forcefully after 3 seconds.</li> <li>Or contact SolaX for help.</li> </ul>
UCellLow_5	<p>Single Cell Undervoltage Category V</p> <ul style="list-style-type: none"> <li>Do not power on, and the charging current is limited to 0 A. If the relay does not receive a power-off instruction from the PCS, it will be turned off forcefully after 3 seconds.</li> <li>Or contact SolaX for help.</li> </ul>
UCellDiff	<p>Voltage difference fault</p> <ul style="list-style-type: none"> <li>Or contact SolaX for help.</li> </ul>
HVBOver_4	<p>Overvoltage category IV of total voltage</p> <ul style="list-style-type: none"> <li>The charging current is limited to 0 A. If the relay does not receive a power-off instruction from the PCS, it will be turned off forcefully after 3 seconds.</li> <li>Or contact SolaX for help.</li> </ul>
HVBOver_5	<p>Overvoltage category V of total voltage</p> <ul style="list-style-type: none"> <li>The charging current is limited to 0 A. If the relay does not receive a power-off instruction from the PCS, it will be turned off forcefully after 1 second.</li> <li>Or contact SolaX for help.</li> </ul>

Fault code	Description and Diagnosis
HVBLow	<p>Undervoltage category IV of total voltage</p> <ul style="list-style-type: none"> <li>• The charging current is limited to 0 A. If the relay does not receive a power-off instruction from the PCS, it will be turned off forcefully after 1 second.</li> <li>• Or contact SolaX for help.</li> </ul>
HVBLow	<p>Undervoltage category V of total voltage</p> <ul style="list-style-type: none"> <li>• The charging current is limited to 0 A. If the relay does not receive a power-off instruction from the PCS, it will be turned off forcefully after 1 second.</li> <li>• Or contact SolaX for help.</li> </ul>
PosRlyAdh	<p>Sticking contacts of main positive relay</p> <ul style="list-style-type: none"> <li>• The charging current is limited to 0 A. If the relay does not receive a power-off instruction from the PCS, it will be turned off forcefully after 1 second.</li> <li>• Or contact SolaX for help.</li> </ul>
PosRlyOpen	<p>Open circuit of main positive relay</p> <ul style="list-style-type: none"> <li>• The charging current is limited to 0 A. If the relay does not receive a power-off instruction from the PCS, it will be turned off forcefully after 1 second.</li> <li>• Or contact SolaX for help.</li> </ul>
TempHigh	<p>Overtemperature fault</p> <ul style="list-style-type: none"> <li>• The charging current is limited to 0 A. If the relay does not receive a power-off instruction from the PCS, it will be turned off forcefully after 1 second.</li> <li>• Or contact SolaX for help.</li> </ul>
TLineFlt_1	<p>Temperature sampling fault level 1</p> <ul style="list-style-type: none"> <li>• Check if the temperature sensor is short-circuited.</li> <li>• Or contact SolaX for help.</li> </ul>
TLineFlt_4	<p>Temperature sampling fault level 4</p> <ul style="list-style-type: none"> <li>• The charging current is limited to 0 A. If the relay does not receive a power-off instruction from the PCS, it will be turned off forcefully after 3 seconds.</li> <li>• Or contact SolaX for help.</li> </ul>
TempLow	<p>Low-temperature fault</p> <ul style="list-style-type: none"> <li>• The charging current is limited to 0 A. If the relay does not receive a power-off instruction from the PCS, it will be turned off forcefully after 1 second.</li> <li>• Or contact SolaX for help.</li> </ul>

Fault code	Description and Diagnosis
DsgOver_4	<p>Discharge overcurrent fault level 4</p> <ul style="list-style-type: none"> <li>• The charging current is limited to 0 A. If the relay does not receive a power-off instruction from the PCS, it will be turned off forcefully after 3 seconds.</li> <li>• Or contact SolaX for help.</li> </ul>
DsgOver_5	<p>Discharge overcurrent fault level 5</p> <ul style="list-style-type: none"> <li>• The charging current is limited to 0 A. If the relay does not receive a power-off instruction from the PCS, it will be turned off forcefully after 1 second.</li> <li>• Or contact SolaX for help.</li> </ul>
ChgOver_4	<p>Charge overcurrent fault level 4</p> <ul style="list-style-type: none"> <li>• The charging current is limited to 0 A. If the relay does not receive a power-off instruction from the PCS, it will be turned off forcefully after 3 seconds.</li> <li>• Or contact SolaX for help.</li> </ul>
ChgOver_5	<p>Charge overcurrent fault level 5</p> <ul style="list-style-type: none"> <li>• The charging current is limited to 0 A. If the relay does not receive a power-off instruction from the PCS, it will be turned off forcefully after 1 second.</li> <li>• Or contact SolaX for help.</li> </ul>
ICOMFault	<p>Internal communication fault</p> <ul style="list-style-type: none"> <li>• Do not power on, and the charging current is limited to 0 A. If the relay does not receive a power-off instruction from the PCS, it will be turned off forcefully after 1 second.</li> <li>• Or contact SolaX for help.</li> </ul>
OCOMFault	<p>External communication fault</p> <ul style="list-style-type: none"> <li>• Do not power on, and the charging current is limited to 0 A. If the relay does not receive a power-off instruction from the PCS, it will be turned off forcefully after 1 second.</li> <li>• Or contact SolaX for help.</li> </ul>
MCOMFault	<p>Intermediate network communication fault</p> <ul style="list-style-type: none"> <li>• Do not power on, and the charging current is limited to 0 A.</li> <li>• Or contact SolaX for help.</li> </ul>
UCellLineOpenFlt	<p>Voltage sampling fault</p> <ul style="list-style-type: none"> <li>• The charging current is limited to 0 A. If the relay does not receive a power-off instruction from the PCS, it will be turned off forcefully after 1 second.</li> <li>• Or contact SolaX for help.</li> </ul>

Fault code	Description and Diagnosis
VoltSensorFlt	Voltage sensor fault <ul style="list-style-type: none"><li>• The charging current is limited to 0 A. If the relay does not receive a power-off instruction from the PCS, it will be turned off forcefully after 1 second.</li><li>• Or contact SolaX for help.</li></ul>
CurrSensorFlt	Current sensor fault <ul style="list-style-type: none"><li>• Contact SolaX for help.</li></ul>
NegRlyAdh	Sticking contacts of main negative relay <ul style="list-style-type: none"><li>• Restart the device.</li><li>• Or contact SolaX for help.</li></ul>
NegRlyOpen	Open circuit of main negative relay <ul style="list-style-type: none"><li>• Restart the device.</li><li>• Or contact SolaX for help.</li></ul>
FlashFlt	Flash fault <ul style="list-style-type: none"><li>• Check if the external Flash communication is normal.</li><li>• Or contact SolaX for help.</li></ul>
ChgReqFlt	Charging request fault <ul style="list-style-type: none"><li>• Check the device is properly charged.</li><li>• Or contact SolaX for help.</li></ul>
InsFlt	Insulation fault <ul style="list-style-type: none"><li>• The charging current is limited to 0 A. If the relay does not receive a power-off instruction from the PCS, it will be turned off forcefully after 1 second.</li><li>• Or contact SolaX for help.</li></ul>
SOCLowFlt	Low SOC <ul style="list-style-type: none"><li>• Check if the device is running out of power.</li><li>• Or contact SolaX for help.</li></ul>
PreChgFailFlt	External short-circuit fault <ul style="list-style-type: none"><li>• The charging current is limited to 0 A. If the relay does not receive a power-off instruction from the PCS, it will be turned off forcefully after 1 second.</li><li>• Or contact SolaX for help.</li></ul>
AFEProtectFlt	Battery's hardware protection fault <ul style="list-style-type: none"><li>• The charging current is limited to 0 A. If the relay does not receive a power-off instruction from the PCS, it will be turned off forcefully after 1 second.</li><li>• Or contact SolaX for help.</li></ul>

---

Fault code	Description and Diagnosis
SelfCheckFlt	<p>Self-test fault</p> <ul style="list-style-type: none"> <li>• The charging current is limited to 0 A. If the relay does not receive a power-off instruction from the PCS, it will be turned off forcefully after 1 second.</li> <li>• Or contact SolaX for help.</li> </ul>
LinkerTempHilFlt_3	<p>Fault on overtemperature of high-voltage connector</p> <ul style="list-style-type: none"> <li>• Check whether the charge/discharge current is over 50% of rated charge/discharge current.</li> <li>• Or contact SolaX for help.</li> </ul>
LinkerTempHilFlt_5	<p>Fault on overtemperature of high-voltage connector</p> <ul style="list-style-type: none"> <li>• Check whether the charge/discharge current is over 50% of rated charge/discharge current.</li> <li>• Or contact SolaX for help.</li> </ul>
BatLinkerTempHi_5	<p>High-temperature fault of pole</p> <ul style="list-style-type: none"> <li>• The charging current is limited to 0 A. If the relay does not receive a power-off instruction from the PCS, it will be turned off forcefully after 3 seconds.</li> <li>• Or contact SolaX for help.</li> </ul>
FanFault	<p>Fan fault</p> <ul style="list-style-type: none"> <li>• Check whether any foreign objects stick to the fan.</li> <li>• Contact SolaX for help.</li> </ul>
FuseSt	<p>Fuse fault</p> <ul style="list-style-type: none"> <li>• Contact SolaX for help.</li> </ul>
DCSwitch	<p>DC switch fault</p> <ul style="list-style-type: none"> <li>• Contact SolaX for help.</li> </ul>

### 10.3 Maintenance

Regular maintenance is required for the device. The table below lists the operational maintenance for expressing the optimum device performance. More frequent maintenance service is needed in the worse work environment. Please make records of the maintenance.



- Before replacing the battery pack, remove the MSD plug, and power off the system to avoid the risk of electric shock.
- Do not use a wet cloth to clean the copper busbar or other conductive parts.
- Do not use water or any solvents to clean the battery.

 **WARNING!**

- Maintenance of the battery must not be performed while the battery is live. Operations such as torque verification and tightening of screws must be done after the battery is powered off. These operations can only be carried out after explaining the risks to the customer, obtaining written consent, and implementing effective preventive measures.
- Only qualified person can perform the maintenance for the device.
- Only use the spare parts and accessories approved by SolaX for maintenance.

 **CAUTION!**

Operation and Maintenance Safety Requirements:

- Before connecting or disconnecting cables, ensure that the protection switch for the corresponding circuit is turned off.
- Use a voltage tester rated for the corresponding voltage level to check for live power, ensuring the equipment is completely powered off.
- If there are live components nearby, use insulating boards or insulating tape to cover or wrap them.
- After securely connecting the maintenance circuit to the main grounding circuit with a grounding wire, proceed with operation and maintenance.
- After completing the maintenance, remove the grounding wire between the maintenance circuit and the main grounding circuit.

**NOTICE!**

- We recommend not opening the door during rainy or high-humidity weather, such as when the relative humidity is consistently above 80%.
- If the door must be opened during rainy weather, the cabinet should be shielded to prevent water from entering and damaging the internal modules.
- Additionally, when opening the cabinet door in high-humidity conditions for more than 0.5 hours, manual forced dehumidification must be performed in both off-grid and grid-connected scenarios to prevent equipment failure or network collapse.

### 10.3.1 Maintenance of the Cabinet

Table 10-2 Maintenance list of cabinet

Item	Check Notes	Maintenance Interval
Cabinet appearance	<ul style="list-style-type: none"> <li>No obvious coating peeling or scratches.</li> <li>No noticeable paint peeling or rust.</li> <li>No damage to the door lock.</li> <li>No dust accumulation.</li> <li>No entry of insects, rodents, snakes, or more.</li> </ul>	Every 12 months
Explosion vent	<ul style="list-style-type: none"> <li>No noticeable paint peeling or rust.</li> <li>The explosion vent plate is not damaged.</li> <li>No foreign objects or snow/ice accumulation on the top.</li> </ul>	Every 12 months

### 10.3.2 Maintenance of the PCS

Table 10-3 Maintenance list of PCS

Item	Check Notes	Maintenance Interval
Operation status	<ul style="list-style-type: none"> <li>No damage or deformation on the appearance.</li> <li>No unusual sounds during operation.</li> <li>All parameters are correctly set during equipment operation.</li> </ul>	Every 12 months
Electric connection	<ul style="list-style-type: none"> <li>No cables are loose or disconnected.</li> <li>Check for any cable damage, focusing on the areas where the cable contacts metal surfaces for signs of cuts or abrasions.</li> </ul>	Every 12 months
Grounding reliability	The grounding cable is properly grounded.	Every 12 months

### 10.3.3 Maintenance of the Battery Pack

Table 10-4 List of general maintenance

Item	Check Notes	Maintenance Interval
Coolant inlet and outlet	There is no coolant leakage at the PACK coolant inlet and outlet.	Every 12 months
Pack appearance	There is no obvious damage, paint peeling, or rust.	Every 12 months
Cable connections	<ul style="list-style-type: none"> <li>No cables are loose or disconnected.</li> <li>Check for any cable damage, focusing on the areas where the cable contacts metal surfaces for signs of cuts or abrasions.</li> </ul>	Every 12 months
Grounding reliability	The grounding cable is properly grounded.	Every 12 months

Table 10-5 List of charging requirements

Circumstance	Measure
If the ambient temperature for storage is between 30°C and 50°C	Recharge the battery packs at least once every 6 months
If the ambient temperature for storage is between -20°C and 30°C	Recharge the battery packs at least once every 12 months.
In the first installation	The interval among manufacture dates of battery packs shall not be exceed 3 months.
If a battery pack is replaced or added for capacity expansion	Each battery's SOC should be consistent. The max. SOC difference should be $\pm 5\%$ .
If users want to increase their battery system capacity	Ensure that the SOC of the existing system capacity is about 40%. The manufacture date of the new battery pack shall not exceed 6 months. If the manufacture date of the new one exceeds 6 months, please charge it to around 40%.



**WARNING!**

- Only qualified person can perform the maintenance for the device.

### 10.3.4 Maintenance of the Liquid Cooling Unit

Table 10-6 Maintenance list of liquid cooling unit

Item	Check Notes	Maintenance Interval
Operation status	<ul style="list-style-type: none"> <li>• The chiller is clean and dust-free and free of dirt.</li> <li>• The chiller operates without abnormal vibration and noise.</li> </ul>	Every 12 months
Pipeline reliability	<ul style="list-style-type: none"> <li>• The refrigeration system has no refrigerant leakage.</li> <li>• The coolant circulation system has no leakage.</li> </ul>	Every 12 months
Filter cleaning	The filter screen is free from dust accumulation, foreign object, blockage, and damage.	Every 12 months
Reliability of power cable and power terminal of wiring panel	<ul style="list-style-type: none"> <li>• No looseness of electrical cables and terminals.</li> <li>• There is no aging, damage, abnormal heating and other abnormalities in the power cable.</li> <li>• There is no dust at the wiring panel.</li> </ul>	Every 12 months
Coolant	<ul style="list-style-type: none"> <li>• Concentration meets range requirements</li> <li>• The PH value and the concentration of each electrolyte meet the requirements. See <i>Maintenance Manual</i> for details.</li> <li>• No dirt, precipitation, algae, etc.</li> </ul>	Every 12 months

# 11 Dispose of Wasted and Damaged Battery Pack

---

Please dispose of the rechargeable battery or accessories in accordance with the disposal regulations for electronic waste which is applied at the installation site.

## NOTICE!

The expenses for dispose of the wasted or damaged battery packs incurred shall be borne by the user.

# 12 Technical Data

## General Parameter

Model	TRENE-P65B261L-E	TRENE-P79B261L-E	TRENE-P99B261L-E	TRENE-P100B261L-E	TRENE-P124B261L-E	TRENE-P125B261L-E
Rated AC Voltage	3 / N / PE, 230 / 400 V 3 / N / PE, 220 / 380 V					
Charging/Discharging Power	65 kW	79.9 kW	99.9 kW	100 kW	124.9 kW	125 kW
Rated Grid Frequency	50/60 Hz					
Max. AC Current	98.5 a.c. A@220 V 94.3 a.c. A@230 V	121.1 a.c. A@220 V 115.8 a.c. A@230 V	151.4 a.c. A@220 V 144.8 a.c. A@230 V	166.7 a.c. A@220 V 159.5 a.c. A@230 V	189.3 a.c. A@220 V 181.1 a.c. A@230 V	189.4 a.c. A@220 V 181.2 a.c. A@230 V
Conditional Short-circuit Current (I <sub>cc</sub> )	< 10000 A					
Output Short Circuit Current	560 A					
Auxiliary Power Input Voltage	L / N / PE, 220, 230 a.c. V					
Auxiliary Power Input Current	10 a.c. A					
Auxiliary Power Frequency	50/60 Hz					
Operating Temperature	-30°C to +55°C					
Protective Class	I					
Altitude	Below 3000 m					
Dimensions (W x H x D)	1350 mm x 1350 mm x 2355 mm					
Weight	2810 kg					
Ingress Protection	IP55					

## Technical Data

---

### Battery Side

---

Product Name	TRENE-B261L
Battery Type	LiFePO4
Rated Capacity	314 Ah
Rated DC Voltage	832 d.c. V
Rated Energy	261 kWh
DC Voltage Range	689–936 d.c.V
Max. Charging/Discharging Power	125 kW
Conditional Short-circuit Current (I <sub>cc</sub> )	< 10000 A
Short-circuit Current/Duration	17.4 kA/1.4 ms
Charge/Discharge Temperature	-30°C to +55°C
Storage Temperature	50°C to 60°C (3 months) 30°C to 50°C (6 months) -20°C to 30°C (12 months)
Auxiliary Power Input Voltage	L/N/PE, 230 a.c. V
Auxiliary Power Input Current	Max. 10 a.c. A
Auxiliary Power Frequency	50/60 Hz
Altitude	Below 3000 m
Ingress Protection	IP55
Protection Class	I

---

## Wireless Technical Specification

Operating Frequency Band	<ul style="list-style-type: none"> <li>• 2.4G Wi-Fi: 2412-2472MHz (TX/RX), 2422-2462MHz (TX/RX)</li> <li>• GSM 900: 880-915MHz (TX), 925-960MHz (RX)</li> <li>• GSM 1800: 1710-1785MHz (TX), 1805-1880MHz (RX)</li> <li>• WCDMA Band I:1920-1980MHz (TX), 2110-2170 MHz (RX)</li> <li>• WCDMA Band VIII: 880-915 MHz (TX), 925-960 MHz (RX)</li> <li>• LTE Band 1: 1920-1980MHz (TX), 2110-2170MHz (RX)</li> <li>• LTE Band 3: 1710-1785MHz (TX), 1805-1880MHz (RX)</li> <li>• LTE Band 7: 2500-2570MHz (TX), 2620-2690MHz (RX)</li> <li>• LTE Band 8: 880-915MHz (TX), 925-960MHz (RX)</li> <li>• LTE Band 20: 832-862MHz (TX), 791-821MHz (RX)</li> <li>• LTE Band 28: 703-748MHz (TX), 758-803MHz (RX)</li> <li>• LTE Band 38: 2570-2620MHz (TX), 2570-2620MHz (RX)</li> <li>• LTE Band 40: 2300-2400MHz (TX), 2300-2400MHz (RX)</li> </ul>
--------------------------	--

Maximum Output Power	2.4G Wi-Fi: 16.56dBm (e.i.r.p.)
----------------------	---------------------------------

Maximum Conducted Output Power	<ul style="list-style-type: none"> <li>• GSM 900: <math>\leq 35</math>dBm</li> <li>• GSM 1800: <math>\leq 32</math>dBm</li> <li>• WCDMA: <math>\leq 25</math>dBm</li> <li>• LTE: <math>\leq 25</math>dBm</li> </ul>
--------------------------------	---

# 13 Appendix

## 13.1 Installation Video

A QR code for the installation video is on the front of the cabinet. Simply scan it with your phone (iOS or Android) to watch the video.

**NOTICE!**

The installation video is provided for reference only, and might be updated as needed. Please install the cabinet following the installation manual and local regulations.



Figure 13-1 Scanning to view the installation video

## 13.2 Requirements for OT/DT Terminal

For different types of cables, select proper terminals and additional components for connection.

**CAUTION!**

Do not connect the aluminum wiring terminal directly to the terminal block or copper bar in case of electrochemical corrosion, which might affect the reliability of cable connection.

**NOTICE!**

The copper–aluminum bimetallic terminal used in scenario 3 must comply with the requirements in IEC61238-1.

Table 13-1 Terminal requirements for different types of cables

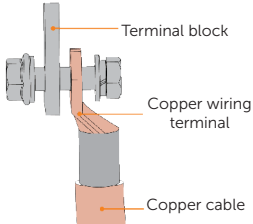
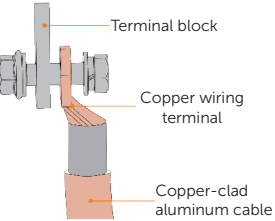
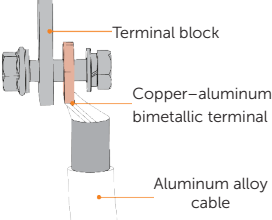
Scenario	Cable Type	Wiring Terminal Type	Figure Illustration
1	Cooper cable	Copper wiring terminal	 <p>The diagram shows a cross-section of a copper cable (orange) inserted into a copper wiring terminal (orange) which is mounted on a terminal block (grey). Labels point to the Terminal block, Copper wiring terminal, and Copper cable.</p>
2	Copper-clad aluminum cable	Copper wiring terminal	 <p>The diagram shows a cross-section of a copper-clad aluminum cable (orange outer layer, grey inner core) inserted into a copper wiring terminal (orange) which is mounted on a terminal block (grey). Labels point to the Terminal block, Copper wiring terminal, and Copper-clad aluminum cable.</p>
3	Aluminum alloy cable	Copper–aluminum bimetallic terminal	 <p>The diagram shows a cross-section of an aluminum alloy cable (grey) inserted into a copper-aluminum bimetallic terminal (orange and grey) which is mounted on a terminal block (grey). Labels point to the Terminal block, Copper–aluminum bimetallic terminal, and Aluminum alloy cable.</p>

### 13.3 How to Repaint the Cabinet

Check the paint damage on the surface of the cabinet, with details below:

- For light scratches or small areas of stubborn stains, please see "13.3.1 Light Scratches & Small Areas of Stubborn Stains" to treat them.
- If the deep scratches or large areas of stubborn stains can be treated by users, please refer to "13.3.2 Deep Scratches and Large Areas of Stubborn Stains".
- If the damaged area is too large and cannot be treated, please contact the after-sale personnel for assistance.

 **WARNING!**

- If the cabinet is installed outdoors without shield, do not repaint it in rainy, snowy, windy, or stormy days.

**NOTICE!**

- Use paint of PANTONE 11-4202TPG color.
- For light scratches and small areas of stubborn stains, spray paint and hairbrush are recommended.
- For deep scratches or large areas of stubborn stains, oil paint and paint sprayer are recommended.

#### 13.3.1 Light Scratches & Small Areas of Stubborn Stains

This solution applies to light scratches without reaching the steel substrate and stubborn stains on the surface.

#### Tools and Materials Required

Prepare tools and enough materials according to actual conditions.

Table 13-2 Tools and materials

No.	Tool/Material	No.	Tool/Material
1	Spray/oil paint	2	Fine sandpaper
3	Anhydrous ethanol	4	Cotton cloth
5	Hairbrush (for small scratched area)	6	Spray paint (if there is a large area of light scratch, paint sprayer is recommended.)

## Repainting Procedure

**Step 1:** Gently sand the scratched area with a fine sandpaper to remove rust and stains on the surface.

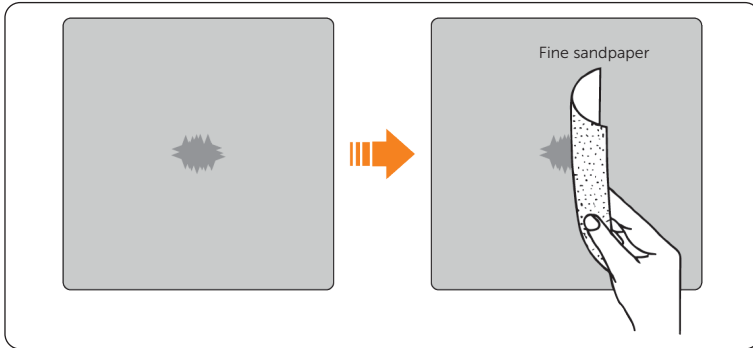

Figure 13-1 Sanding the scratched area

**Step 2:** Moisten a cotton cloth with anhydrous ethanol, wipe the scratched area with it to remove dust and dirt, and then use a dry cotton cloth to wipe the area dry.

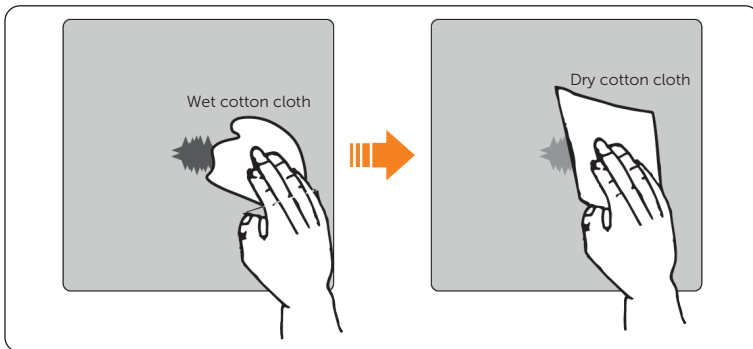

Figure 13-2 Cleaning the scratched area

**Step 3:** Use hairbrush or spray paint to apply paint to the surface of the scratched area until it is fully and evenly covered.

### NOTICE!

- While applying paint, make sure the newly applied paint is thin and even, so that the scratched area can appear consistent and smooth on the surface.
- If there is color difference between the scratched area and the surroundings, cover the surrounding area with tape or paper in case of color contamination.

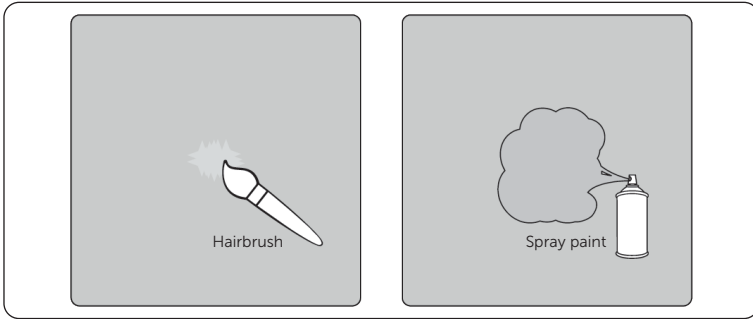

Figure 13-3 Applying paint

**Step 4:** After completing applying the paint, wait for around 30 minutes for the paint to get dry, and then check whether the repaired area meets the requirements.

**NOTICE!**

- The color of the repaired area shall be consistent with the surrounding area.
  - » Use a colorimeter to measure the color difference, of which Delta E shall be  $\leq 3$ .
  - » If the color cannot be measured by a colorimeter, make sure that there is no obvious color difference at the edges between the repaired area and the surrounding area, as well as no bumps, scratches, flakings, or breaks.
- For spray painting, we recommend painting for at least 3 times before pausing to check the effect, and then repeat spray painting and observing until it meets the requirements.

### 13.3.2 Deep Scratches and Large Areas of Stubborn Stains

This solution applies to deep scratches where the primer has been damaged and reach the steel substrate.

#### Tools and Materials Required

Prepare tools and enough materials according to actual conditions.

Table 13-3 Tools and materials

No.	Tool/Material	No.	Tool/Material
1	Spray/oil paint	2	Zinc-rich primer
3	Fine sandpaper	4	Anhydrous ethanol
5	Cotton cloth	6	Hairbrush (for small areas of deep scratches and stubborn stains)
7	Paint sprayer (for large areas of deep scratches and stubborn stains)		

## Repainting Procedure

**Step 1:** Gently sand the scratched area with a fine sandpaper to remove rust and stains on the surface.

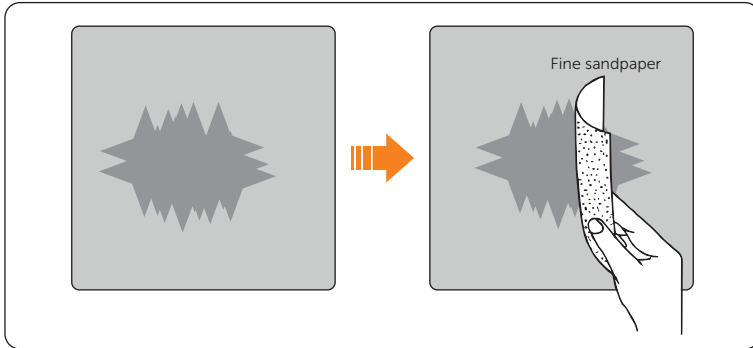

Figure 13-4 Sanding the scratched area

**Step 2:** Moisten a cotton cloth with anhydrous ethanol, wipe the scratched area with it to remove dust and dirt, and then use a dry cotton cloth to wipe the area dry.

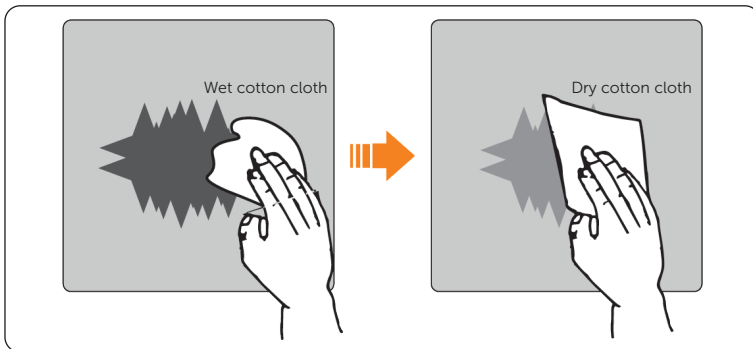

Figure 13-5 Cleaning the scratched area

**Step 3:** Use a paint spray to apply the zinc-rich primer to the scratched area.

### NOTICE!

- If the steel substrate is visible on the scratched area, the zinc-rich primer must be applied first to entirely cover the substrate.
- Wait for the primer to get dry before applying the top coat to the scratched area.

**Step 4:** Use a paint spray to apply paint to the surface of the scratched area until it is fully and evenly covered.

**NOTICE!**

- While applying paint, make sure the newly applied paint is thin and even, so that the scratched can appear consistent and smooth on the surface.
- If there is color different between the scratched area and the surroundings, cover the surrounding area with tape or paper in case of color contamination.

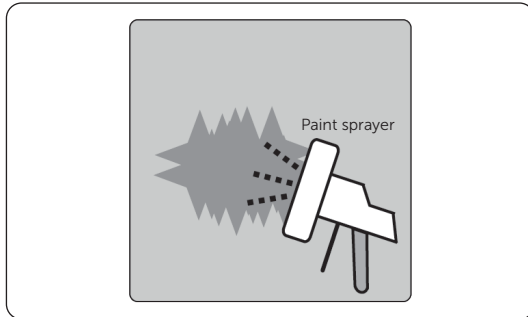

Figure 13-6 Applying paint

**Step 5:** After completing applying the paint, wait for around 30 minutes for the paint to get dry, and then check whether the repaired area meets the requirements.

**NOTICE!**

- The color of the repaired area shall be consistent with the surrounding area.
  - » Use a colorimeter to measure the color difference, of which Delta E shall be  $\leq 3$ .
  - » If the color cannot be measured by a colorimeter, make sure that there is no obvious color difference at the edges between the repaired area and the surrounding area, as well as no bumps, scratches, flakings, or breaks.
- For spray painting, we recommend painting for at least 3 times before pausing to check the effect, and then repeat spray painting and observing until it meets the requirements.

### 13.3.3 Logo & Pattern damaged, Dents or Dings

In this case, we recommend contacting a local spray painting company for customized treatment based on the actual conditions.

Table 13-4 Damage extent and recommended solution

No.	Damaged Area	Recommended Solution
1	<ul style="list-style-type: none"> <li>• Size &lt; 100 mm<sup>2</sup></li> <li>• Depth &lt; 3 mm</li> </ul>	Use a poly-putty base to fix the dents and dings first, and then deal with them according to " <a href="#">Repainting Procedure</a> " for Deep Scratches.
2	<ul style="list-style-type: none"> <li>• Size &gt; 100 mm<sup>2</sup></li> <li>• Depth &gt; 3 mm</li> </ul>	Contact local supplier to make a plan for repair.



## **SolaX Power Network Technology (Zhejiang) Co., Ltd.**

Add.: No. 278, Shizhu Road, Chengnan Sub-district, Tonglu County,  
Hangzhou, Zhejiang, China  
E-mail: [info@solaxpower.com](mailto:info@solaxpower.com)